

## Stainless Steel Utility Carts

### Extreme Duty® - 1500 Lb Capacity



Model 8840



Model 8820



### Models 8820, 8840

#### Designed Rugged Correctional Facility And 24-Hour Applications.

- Square tubing reinforcement under shelves and square tube frame provides model 8840's superior strength.
- "U" shaped body design with angled stainless steel frame gives model 8820 the Extreme Duty classification.
- All stainless steel construction with full bead welding.
- No pry points.
- Resists staining and rusting, cleans and sanitizes easily.
- 1500 lb. (680 kg.) capacity is ideal for 24-hour operations to transport heavy loads over various indoor or outdoor surfaces.
- Model 8820 is NSF listed.

### Specifications

**Model 8840:** Unit shall be of fully welded stainless steel construction and shall be free of pry points. Legs and frame shall be of inverted U-frame design, constructed of .065 wall x 1" x 1" stainless steel square tubing. Inverted U-frame shall form integrated push handles on both ends. Shelves shall be of 14-gauge stainless steel, and shall be TIG welded to vertical leg frames. Shelves shall be reinforced on four sides with .065 wall x 1" x 1" stainless steel square tubing. Shelves shall also feature three additional reinforcements of .065 wall 1" x 1" stainless steel square tubing running the depth of the shelves. All shelf reinforcements shall be TIG welded to underside of shelves. Unit shall have two each 8" diameter extra-load swivel and two each 8" (203 mm) diameter extra-load fixed casters with 1-1/4" (32 mm) wide non-marking polyurethane wheels. Casters shall be plate type and mounting plate shall be welded to lower frame.

*Specifications continued on back.*

Lakeside Manufacturing, Inc.

4900 West Electric Avenue • West Milwaukee, WI 53219 U.S.A.

800-558-8565 • 414-902-6400 • Fax 414-902-6446 • info@eLakeside.com • www.eLakesideFoodservice.com

# Stainless Steel Utility Carts

Extreme Duty®

AIA #

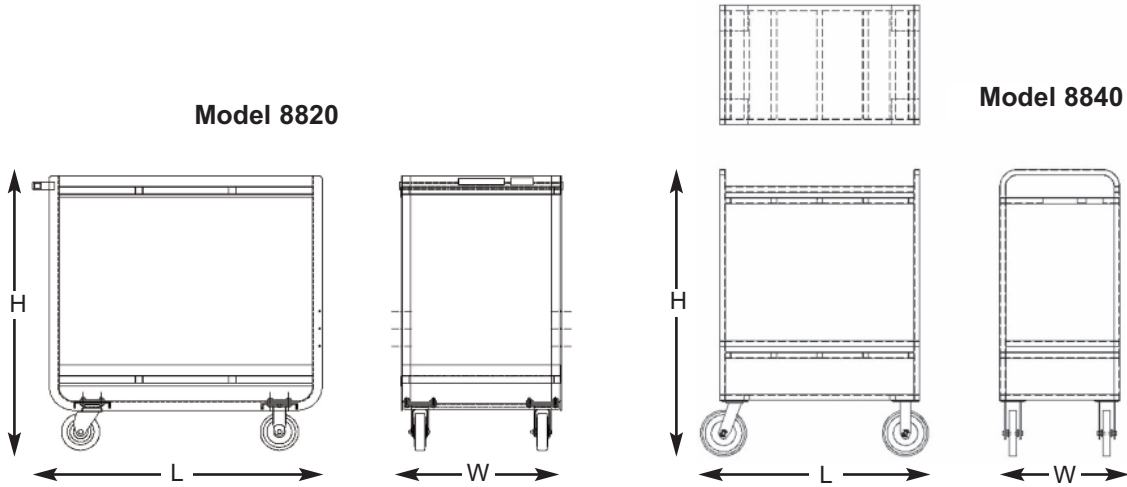

AutoCAD drawings available through KCL CADalog

Spec. #

## Specifications (continued)

**Model 8820:** Unit shall be of fully welded stainless steel construction and shall be free of pry points. Legs and frame shall be of U-frame design, eliminating the need for corner reinforcements. Leg/frame shall be constructed of .120 x 1" x 1" angle stainless steel. Shelves shall be of 14-gauge stainless steel and shall be continuously TIG welded to vertical leg frames. Shelves shall be reinforced front and back with 18-gauge angle welded to the shelf underside. Shelves shall also feature two additional reinforcements of .065 wall 1" x 1" stainless steel square tubing running the width of the shelves. All shelf reinforcements shall be TIG welded to underside of shelves. Unit shall have two each 5" (127 mm) diameter extra-load swivel and two each 5" (127 mm) extra-load fixed casters with 1-1/4" wide non-marking polyurethane wheels. Casters shall be plate type and shall be bolted to an 18-gauge 5" (127mm) wide stainless steel cross member with a galvanized reinforcement. Unit shall have push handle made of 18 gauge wall 1" O.D. stainless steel tubing. Handle mounting brackets shall be continuously TIG welded to vertical leg frame. Unit shall have two each bumpers mounted to handle ends and two each 6" (203 mm) vertical bumpers riveted to front legs. Unit shall be NSF listed.

### Optional Accessories (Model 8820)

- All 5" (127 mm) swivel casters
- Extended perimeter bumper
- Security packages

## Model Information

Model	Shelf Description			Overall Size			Case Weight	
	# of	Size	Clearance	L	W	H	lb.	(kg.)
8840	2	21" x 33" (533 x 838)	27" (686)	35" (889)	22" (559)	50-1/8" (1273)	117	(53)
8820	2	21" x 33" (533 x 838)	24-5/8" (625)	36-1/2" (927)	21-1/4" (540)	37-7/32" (945)	98	(44)

Measurements in ( ) denote metric millimeters, unless otherwise specified.



Lakeside Manufacturing, Inc.  
4900 West Electric Avenue • West Milwaukee, WI 53219 U.S.A.  
800-558-8565 • 414-902-6400 • Fax 414-902-6446  
info@eLakeside.com • www.eLakesideFoodservice.com