

Project: _____ Location: _____ Item #: _____ Quantity: _____

Standard Features

- c-CSA-us and NSF certified.
- Double wall kettle interior.
- Bottom kettle is hemispherical designed for superior heat circulation.
- Drip proof, stainless steel clad console
- Power Switch, thermostat, pilot light, low water light, vacuum/pressure gauge, safety relief valve and low water shut off.
- Removable Elements.
- "Clean Lock" to hold kettle in cooking position or 105° for ease of cleaning.
- 316 Stainless Steel liner.

Optional Features

- 2" (50 mm) draw-off valve (ACTVT-3).
- Etched gallon markings (ACGM-20.)
- Etched litre markings (ACLM-20).
- Correctional package

Electrical Options

- 208 VAC, 1 phase, 50/60 Hz.
- 208 VAC, 3 phase, 50/60 Hz.
- 220 VAC, 1 phase, 50/60 Hz.
- 220 VAC, 3 phase, 50/60 Hz.
- 240 VAC, 1 phase, 50/60 Hz.
- 240 VAC, 3 phase, 50/60 Hz.
- 380/220 VAC, 3 phase, 50/60 Hz. 4 wire
- 415/240 VAC, 3 phase, 50/60 Hz. 4 wire
- 480 VAC, 3 phase, 50/60 Hz.

Short Spec

Countertop Kettle shall be AccuTemp's ACEC-20T series electric a self-generating, electric, countertop kettle. A double wall kettle interior shall form a steam jacket around the lower 2/3 of the kettle. The jacket enclosure shall contain purified water and is factory sealed. The bottom of the kettle shall be of hemispherical design for superior heat circulation. The mounting base shall include 4 stainless steel legs fitted with a 4 hole adjustable foot for securing unit to the floor.

Construction shall be all welded #4 finish stainless steel, type 304. The liner on this 20 gallon model shall be standard 316 for high acid content cooking. The controls shall be integrally mounted and shall include a power switch, thermostat, pilot light, low water light, vacuum/pressure gauge, safety relief valve, and low water shut off.

The kettle shall be ASME Code stamped, National Board Registered, c-CSA-us and NSF certified.

The kettle shall operate in a temperature range of 165°F to 285°F (74°C to 140°C) at a maximum pressure of 50 psi (345 kPa).

Other Approvals



ACEC-20T Model Shown

Accessories

- One piece lift off stainless steel cover (ACC-20).
- Lift-out perforated stainless steel basket (ACSSB-20).
- Perforated strainer for draw off (ACTPS-2).
- Solid disc for draw off (ACTSS-2).
- Graduated measuring strip (ACGMS-20).
- Strainer hook (ACSH-20)
- Single pantry faucet with swing spout (ACSF-12).
- Double pantry faucet with swing spout (ACDF-12).
- Pour lip strainer (ACTKS-20).
- Calibrated thermostat dial, "F"
- Calibrated thermostat dial, "C"

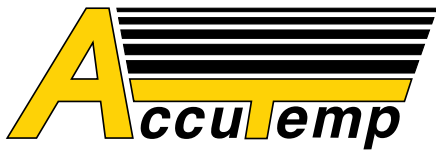

ELECTRIC COUNTER TILTING KETTLE
 20 GALLON CAPACITY—ELECTRIC HEATED, COUNTER
 MANUAL TILT, ELECTRIC KETTLE

Electric Counter Kettle Model "ACEC-20T" Specifications										
AVAILABLE KW			AMPS PER LINE							
Model #	Weight	Capacity	kW	Phase	208V	220V	240V	380V	415V	480V
ACEC-20	225 lbs [102 kg]	20 gallons 76 litres	12	1	57.6	54.5	50.0	n/a	n/a	n/a
				3	33.4	31.5	28.9	18.3	16.7	14.5

Notes:

1. Electrical connection to be specified on the data plate.
2. Hot & Cold Water: 3/8" OD tubing to Faucet (optional).

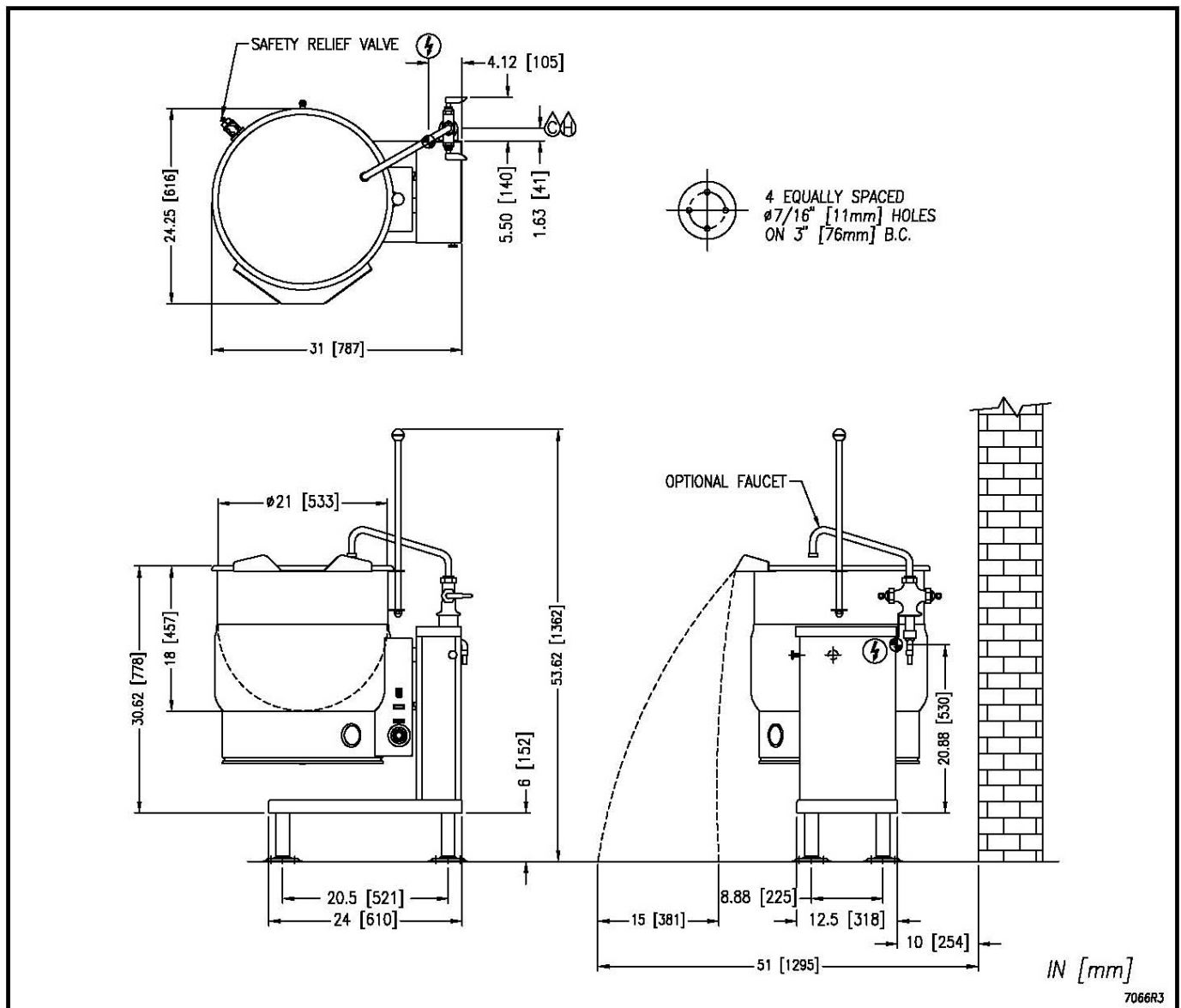

MM6223-1105