

Project: _____ Location: _____ Item #: _____ Quantity: _____

Standard Features

- c-CSA-us and NSF certified.
- All Stainless Steel Exterior.
- Stainless Steel Cover with Spring Assist Hinges.
- Full width handle.
- No-drip Condensate Guide and Vent Port with Swing Cover.
- Easy tilting Pour Control.
- Removable Pour Strainer.
- Pan is 10 gauge Stainless Steel with a #4 finish Exterior, Polished Interior.
- Even Heat Distribution with 5/8" thick Stainless Steel Clad Plate.
- Heavy-Duty welded Frame.
- Adjustable Bullet Front Feet.
- Adjustable Flange Rear Feet.
- Hydraulic Lift System powered by a 1/2HP electric motor for precise tilting motion.

Optional Features

- 18kW elements (40 gallon only).
- Etched gallon markings (ACGMS-30, ACGMS-40).
- Etched litre markings (ACLMS-30, ACLMS-40).
- 2" draw off valve with strainer, front mounted (ACTVT-2BP).
- 3" draw off valve with strainer, side mounted (ACTVT-3BP).
- Correctional Package.

Electrical Options

- 208 VAC, 1 phase, 60 Hz.
- 208 VAC, 3 phase, 60 Hz.
- 220 VAC, 1 phase, 50 Hz.
- 220 VAC, 3 phase, 50 Hz.
- 240 VAC, 1 phase, 60 Hz.
- 240 VAC, 3 phase, 60 Hz.
- 380/220 VAC, 3 phase, 50 Hz. 4-wire.
- 380/220 VAC, 3 phase, 60 Hz. 4-wire.
- 415/240 VAC, 3 phase, 50 Hz. 4-wire.
- 415/240 VAC, 3 phase, 60 Hz. 4-wire.
- 480 VAC, 3 phase, 60 Hz.

Short Spec

Tilting skillet shall be AccuTemp's ACEMTS series electrically heated skillet with hydraulic tilt. The skillet shall have a stainless steel cover with spring assist hinges, full width handle, no-drip condensate guide and vent port with swing cover. Powerful hydraulic lift system powered by a 1/2 HP electrical motor for smooth and precise tilting action. The pan shall have a sloped front and front hinged for easy tilting pour control and comes complete with a removable pour strainer. Stainless steel construction featuring covered corners for ease of cleaning. Cooking surface shall be 5/8" thick stainless steel clad plate ensuring even heat distribution over entire cooking surface. The pan shall be fitted with tubular heating elements clamped to the under side.

The pan shall be mounted on a heavy duty frame fitted with stainless steel legs with adjustable bullet feet on the front and flange feet on the rear for securing to the floor. Enclosed with #4 finished type 304 stainless steel with removable side panel and two stainless steel front cabinet doors.

All controls are mounted in the cabinet base which include temperature thermostat, temperature light, tilt switch, high limit thermostat. Cooking temperatures are between 160°F and 445°F (71°C and 229°C).

Other Approvals



ACEMTS-30/40 Model Shown

Accessories

- Pan Carrier (ACPC-3).
- Steam Pan Insert (ACSPI-30, ACSPI-40).
- 12" Single Pantry Faucet with swing spout (ACSF-12).
- 12" Double pantry faucet with swing spout (ACDF-12).
- 3" Stainless Steel faucet plumbing enclosure (AC3139-1).
- Single pantry Kettle Filler, with Bracket (ACSP-KF).
- Double pantry Kettle Filler, with Bracket (ACDP-KF).

Pan Capacities

Pan Size	Gallon	Litre
33.5" x 23.5"	30	114
43.5" x 23.0"	40	152

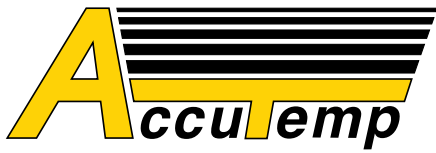

ELECTRIC SKILLET WITH CABINET BASE
 30-40 GALLON CAPACITY—ELECTRIC HEATED,
 ELECTRIC TILT, ELECTRIC SKILLET WITH CABINET BASE

Tilt Skillet Model "ACEMTS" Specifications								
Model #	kW	Phase	AMPS PER LINE					
			208V	220V	240V	380V	415V	480V
ACEMTS-30 (12kW only)	12	1	62.1	58.6	53.9	n/a	n/a	n/a
		3	37.7	35.6	32.8	20.6	18.9	16.3
ACEMTS-40 (15kW)	15	1	76.5	72.3	66.4	n/a	n/a	n/a
		3	46	43.5	40	25.2	23.1	19.9
ACEMTS-40 (18kW)	18	1	90.9	85.9	78.9	n/a	n/a	n/a
		3	54.4	51.3	47.2	29.7	27.2	23.6

Model #	Shipping Weight	Capacity	UNITS	DIMENSIONS							
				A	B	C	D	E	F	G	
ACEMTS-30	617 lbs. [280 kg]	30 gallons 114 litres	inches mm	36.0	30	70.88	33.5	23.5	3.75	Ø2 Ø3	
				914	762	1800	851	597	95	41.13	46.75
ACEMTS-40	770 lbs. [349 kg]	40 gallons 152 litres	inches mm	48.0	42.0	70.88	43.5	23.0	4.75	41.63	46.13
				1219	1067	1800	1105	584	121	1057	1172

Notes:

1. Electrical connection to be specified on the data plate.
2. Hot & Cold Water: 3/8" OD tubing to Faucet (optional).

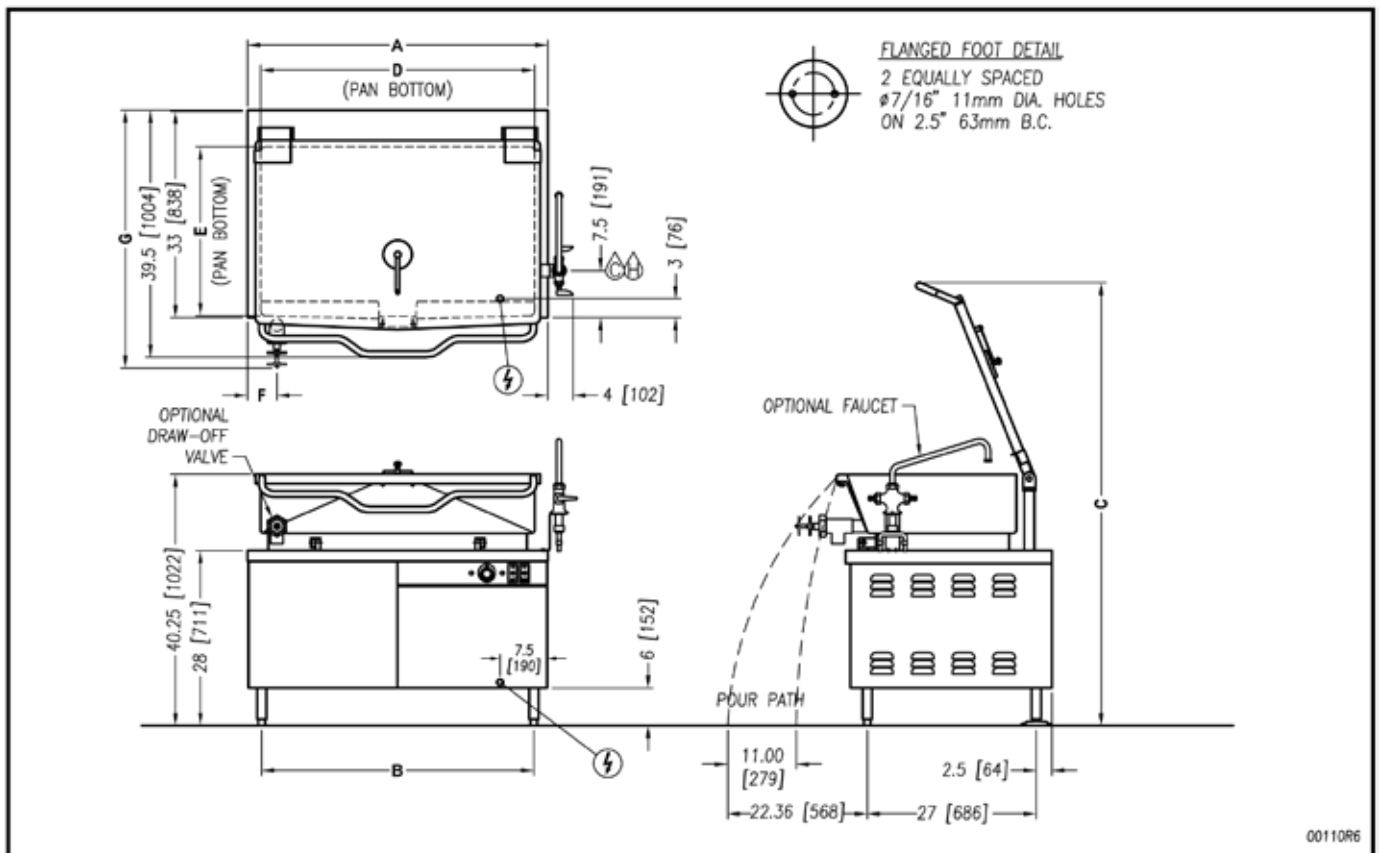

00110R6