

# MODEL AD-21W

## Glasswasher



Item # \_\_\_\_\_

### Standard Features

- **High temperature** sanitation to protect your ware from harmful chemicals during final rinse. Your glasses will come out cleaner and dryer than conventional sanitation methods.
- Electronical controls for a precise wash with 3 programmed wash cycles to handle your specific needs. **27 Racks per hour capacity.**
- Built-in **electric booster heater** that will raise the temperature to the NSF required temperature of 180°F for sanitation.
- Unique **“Manual Cool Water Rinse”** designed specifically for bar applications to cool your glasses and provide a damp glass for your glass froster.
- **Auto-fill** will take the guess work of filling your machine to ensure the proper water levels in your unit at all times.
- Built-in drain pump, **detergent & rinse pumps** come standard to give you all the options necessary to run your glasswasher.
- (2) Flat 16” x 16” racks, (1) Cutlery and (1) Supplement for dishes are included.



### Specifier Statement

Specified unit will be a Fagor AD-21W undercounter, front loading, high temperature glasswasher with built-in booster heater. Features electronical controls with 3 time settings, Unique “Manual Cool Water Rinse” to bring the temperature of your ware down so it is cool to the touch. Constructed in stainless steel including tops and side panels. Standard with liquid detergent, liquid rinse and drain pumps, cord, plug, fill and drain hose. 90 days labor / one year parts warranty.

### Options & Accessories

- All purpose 16” x 16” flat racks
- Cutlery container
- Supplement for dishes
- 9 or 16 compartment rack inserts
- 6” base with legs
- Drain water tempering valve
- Water pressure regulating valve with guage



Capacities		Water Consumption		Temperatures	
<b>Racks Per Hr.</b>	27	<b>Gallons Per Hr.</b>	17.6 gal. / 66.6 litre	<b>Wash</b>	150°F / 66°C
<b>Glasses Per Hr.</b>	972	<b>Gallons Per Cycles</b>	.65 gal. / 2.4 litre	<b>Rinse</b>	190°F / 88°C
<b>Wash Tank</b>	4 gal. / 15.4 litre	<b>Inlet Temperature (optimum)</b>	140°F / 60°C		
		<b>Flow Rinse Pressure</b>	25 psi		
Operating Cycles*		Heating & Wash Pump Motor		Dimensions	
<b>Wash Time (seconds)</b>	70	<b>Electric Wash Tank Heater</b>	2 kw	<b>Width</b>	18-1/2" (469.9 mm)
<b>Dwell (seconds)</b>	5	<b>Electric Booster Heater</b>	2.8 kw	<b>Depth</b>	20-1/2" (520.7 mm)
<b>Rinse Time (seconds)</b>	15	<b>Motor (hp)</b>	1/3 hp	<b>Height</b>	28-1/3" (719.58 mm)
<b>Total Time (seconds)</b>	90	<b>NEMA Plug</b>	6-20p	<b>Max. Clearance</b>	10 -1/2" (267 mm)
				<b>Shipping Weight</b>	105 lbs (47.5 kg)
				<b>Shipping Volume (cu. ft.)</b>	10

# Specifications Model AD-21W

## Cabinet

Constructed of high-quality stainless steel, type 304 top and sides. Back is constructed of Galvanized aluminum. Interior cabinet is completely constructed in high-quality 16 gauge, 304 stainless steel. Door is completely stainless steel with a brushed aluminum door handle. Built-in electric booster heater, all stainless steel construction with 2.8 kw elements with infinite rise in water temperature. Wash tank has a 2.0 kw element design to maintain water above 150°F. Wash and Rinse

arms are one piece, both upper and lower, stainless steel with high impact plastic rinse nozzles. Unit comes standard on 1-1/2" adjustable legs.

## Controls

Controls are located on the top front of the machine. Digital temperature displays for wash and booster tanks. Water resistant start button. (3) time settings (90, 120 & 180 sec.) and (1) drain setting. Automatic fill and door safety switch. Power light and running light.

## Others

Built in detergent and rinse pumps—Std. Built in drain pump with accessibility in the front. Unit is 100% serviceable from the front. Built in vacuum breaker and automatic drain. Electrical cord with plug, fill and drain hose included.

## Warranty

90 labor / one year parts. (Continental U.S.A. & Canada only.)

## Service Connections

- A** Water inlet 3/4" Female hose connector on 5' long flexible hose supplied with machine; Adaptor for 3/4" female garden hose fitting also supplied; 140°F / 60°C Optimum water temperature; 25 psi flow rinse pressure.
- D** Drain 5' long, 1/2" I.D. flexible hose. Maximum 26 3/4" drain height permitted, Indirect connection to drain pipe.
- R** Electrical terminal block connection point.
- E** Electric power supply - 6' long electrical cord supplied with machine (NEMA: 6-20p)

**Caution** Before connecting water to this unit, have water supply analyzed to make sure hardness is not greater than 2.0 grains and pH level is within the range of 7.0-8.5. Water which fails to meet these standards should be treated by the installation of a water conditioner. EQUIPMENT FAILURE CAUSED BY INADEQUATE WATER QUALITY IS NOT COVERED UNDER WARRANTY.

**Warning** Installation should be made by qualified personnel who will observe all specified local codes.

Incoming Water Temp	140°F	110°F
Aprox. racks per hour*	27	27

Volts/Hz/Ph	Amps
208/60/1	13
220/60/1	14
240/60/1	15

- 50 Hz models, consult factory  
 \* Approximate based on consistent hot water and constant water pressure.

Front

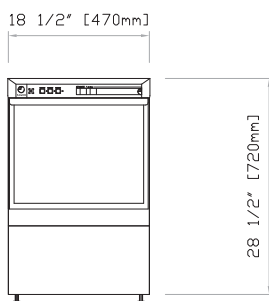

Side

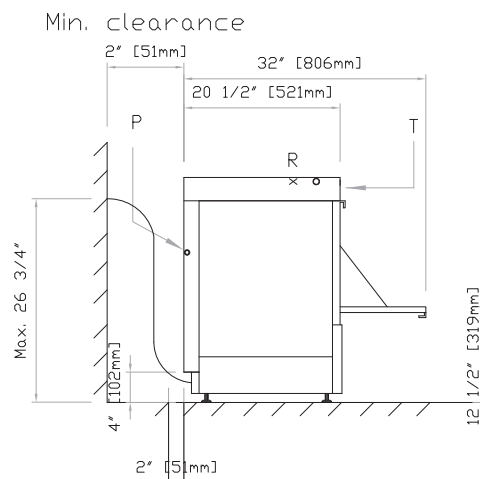

Back

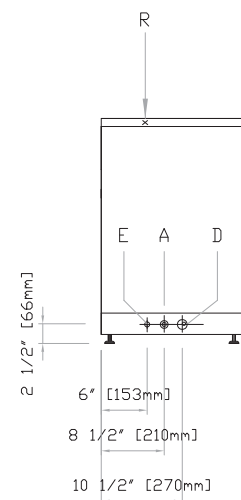

The manufacturer reserves the rights to modify materials and specifications without notice. Printed in the USA • 09/12