



Model #ADD-48

Cooling

Temperature Range	33°F-40°F
Refrigerant	R290
Max. Ambient Temperature	90°F
Defrosting	Automatic
Temperature Controller	Digital
Horsepower	1/5

Electrical

Voltage	115
Amps	3
Hz	60
Phase	1
Plug Type	NEMA-5-15P
Electrical Cord Length	96"

Standard Features – Beer Dispenser Model #ADD-48

- Holds (2) ½ kegs
- Double tap tower with 10-1/4" faucet height
- Includes 2 "D" system keg couplers
- Foamed-in-place polyurethane insulation
- (4) epoxy-coated shelf accommodates up to 90 lb.
- Environmentally-safe R290 refrigerant
- LED lights illuminate interior
- (2) locking self-closing door with recessed handles
- 115V; 1/5 HP
- ETL listed. Conforms to UL STD. 471, Certified to CSA STD. C22. 2No.120
- Conforms to NSF/ANSI STD. 7.

Construction

Exterior Material	Black coated steel
Interior Material	Painted aluminum
Insulation Material	Foamed-In-Place Polyurethane
Shelf	(4) epoxy-coated steel holds up to 90 lb.
Taps	(2) 10-1/4" faucet height

Dimensions

Exterior Dimensions	48-3/4"W x 24-3/8"D x 35-5/8"H
Interior Dimensions	36-1/4"W x 18-1/2"D x 28-7/8"H
Shipping Dimensions	51-1/4"W x 27-1/2"D x 41-3/4"H
Tower Dimensions	16"H 3" Diameter
Net Volume	13 cu. ft.
Net Weight	231 lb.
Gross Weight	275lb.



PLAN VIEW

Front View
Front View

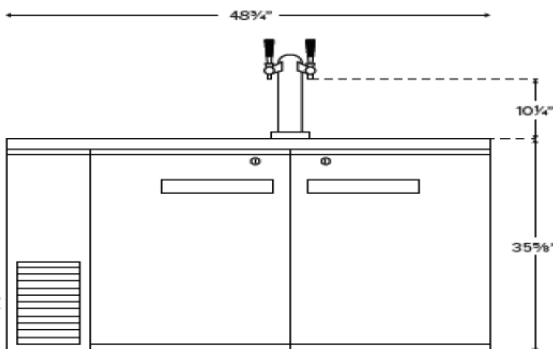

Side View
Side View

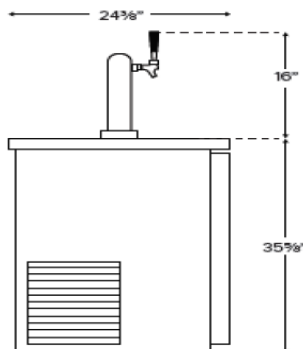

Top View
Top View

