



Model #AF-19

Cooling

Temperature Range	-5°F - 2°F
Refrigerant	R290
Max. Ambient Temperature	90°F
Defrosting	Automatic
Temperature Controller	Digital
Horsepower	3/4

Electrical

Voltage	115
Amps	7.1
Hz	60
Phase	1
Plug Type	NEMA-5-15P
Electrical Cord Length	96"

Standard Features

- Self-closing door with convenient stay-open feature
- Easy-to-clean 430 series stainless steel exterior
- Corrosion-resistant 3014 series stainless steel interior
- Temperature range of (-5)°F - 2°F
- 3 shelves included: versatile shelf slide design also accepts full size food pans
- Environmentally-safe R290 refrigerant
- Digital temperature controller with automatic defrost function
- 115V; 1/5 HP ETL Safety & Sanitation Listed

Construction

Exterior Material	430 Stainless Steel
Interior Material	304 Stainless Steel
Insulation Material	Foamed-In-Place Polyurethane
Shelf Size (3)	20-7/8"W x 25-3/16"D
Shelf Material	Epoxy-Coated Steel
Shelf Load Capacity	120 lbs.

Dimensions

Exterior Dimensions	29"W x 25-1/2"D x 82-1/2"H
Interior Dimensions	24"W x 27 1/2"D x 60"H
Shipping Dimensions	31"W x 27"D x 83"H
Net Volume	19 cu. ft.
Net Weight	236 lbs.
Gross Weight	280 lbs.



Parts & Labor



Compressor

PLAN VIEW

Front View

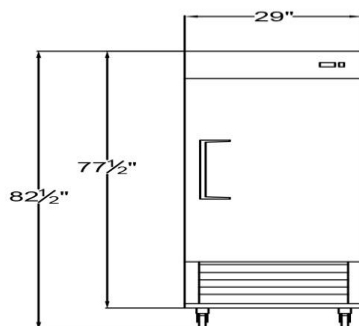

Side View

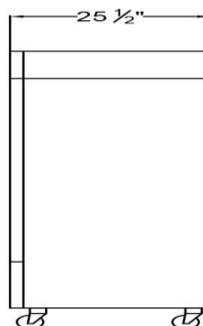

Top View

