



Model #AR-72

Standard Features

- Self-closing doors with convenient stay-open feature
- Easy-to-clean 430 series stainless steel exterior
- Corrosion-resistant 304 series stainless steel interior
- Temperature range of 33-40°F
- 9 shelves included; versatile shelf slide design also accepts full size food pans
- Environmentally-safe R290 refrigerant
- Digital temperature controller with automatic defrost function
- 115V; 3/4 HP
- ETL Safety & Sanitation Listed

Construction

Exterior Material	430 Stainless Steel
Interior Material	304 Stainless Steel
Insulation Material	Foamed-In-Place Polyurethane
Shelf Size	(6) 20-7/8"W x 25-3/16"D & (3) 22-1/8"W x 25-3/16"D
Shelf Material	Epoxy-Coated Steel
Shelf Load Capacity	120 lbs.

Cooling

Temperature Range	33°F - 40°F
Refrigerant	R290
Max. Ambient Temperature	90°F
Defrosting	Automatic
Temperature Controller	Digital
Horsepower	3/4

Electrical

Voltage	115
Amps	9
Hz	60
Phase	1
Plug Type	NEMA-5-15P
Electrical Cord Length	96"

Dimensions

Exterior Dimensions	80-7/8"W x 32-1/4"D x 82-1/2"H
Interior Dimensions	76-1/4"W x 27-1/8"D x 60-1/4"H
Shipping Dimensions	83-1/2"W x 34-3/4"D x 85-1/2"H
Net Volume	66.5 cu. ft.
Net Weight	615 lbs.
Gross Weight	693 lbs.



Parts & Labor



Compressor

PLAN VIEW

Front View

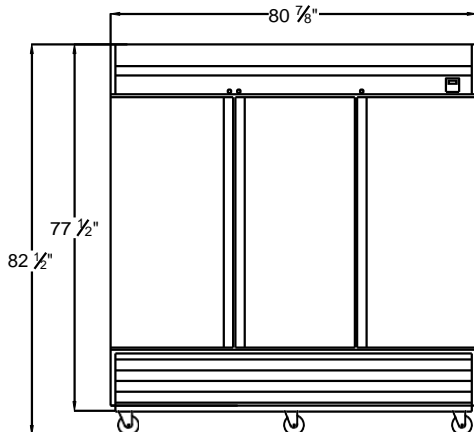

Side View

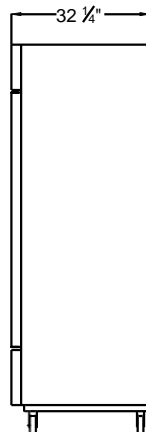

Top View

