

*PLAN VIEW*  
RIGHT HINGE  
SELECT

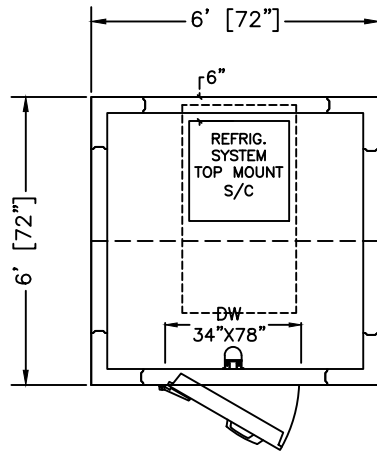

*PLAN VIEW*  
LEFT HINGE  
SELECT

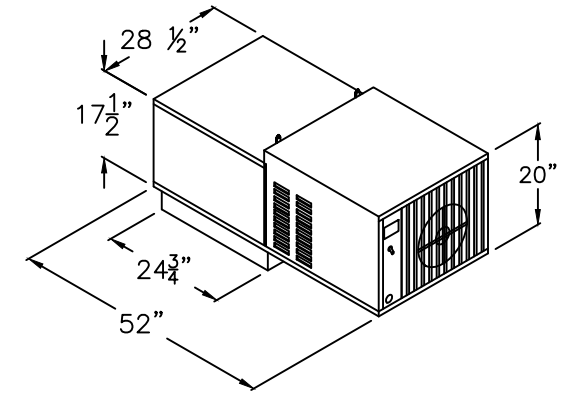
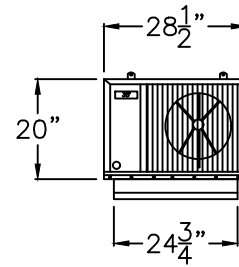

*REFRIGERATION UNIT*

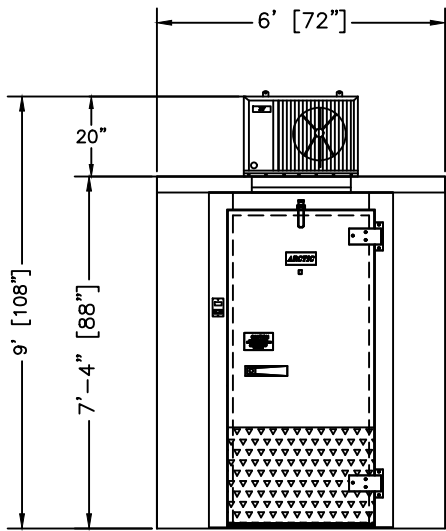

*ELEVATION*  
RIGHT HINGE

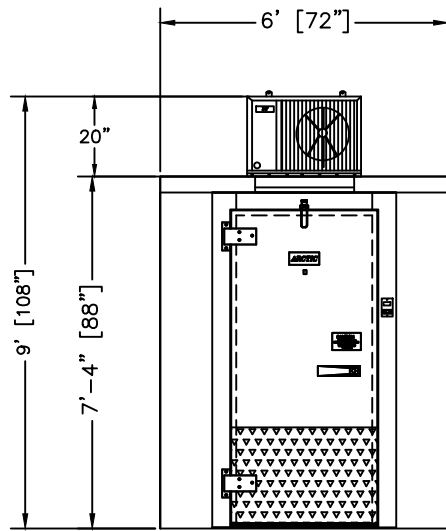

*ELEVATION*  
LEFT HINGE

PRODUCT SPECIFICATIONS	
MODEL:	BL66-C-SC
WALK-IN SPECIFICATION	
INTERIOR/EXTERIOR FINISH	26 GAUGE MILL EMBOSSED ACRYLUME OR 26 GAUGE STUCCO EMBOSSED GALVANIZED STEEL
ELECTRICAL (VOLTS/Hz/PH)	115/60/1
MAX AMP.	0.8
SYSTEM SPECIFICATION	
ELECTRICAL (VOLTS/Hz/PH)	208/230/1/60
AMPS	6.3
WEIGHT (LBS)	195
CORD + NEMA 5-20R PLUG	
WALK-IN AND REFRIGERATION FREIGHT	
TOTAL SHIPPING WEIGHT (LBS)	841
MAXIMUM PALLET SIZE	48" X 96" X 102" HIGH
NUMBERS OF PALLETS	2

MODEL: BL66-C-SC

INDOOR-NO FLOOR

COOLER 35°F

SELF-CONTAINED SYSTEM

CUSTOMER APPROVAL

DATE: \_\_\_\_\_

SIGNATURE: \_\_\_\_\_

THE DRAWINGS, TECHNICAL DATA, AND ALL OTHER INFORMATION SET FORTH IN THIS DOCUMENT COMPRISE TRADE SECRETS AND CONFIDENTIAL INFORMATION THAT IS THE EXCLUSIVE PROPERTY OF ARCTIC INDUSTRIES, LLC.

USE OF SUCH INFORMATION IS LIMITED TO THE PURPOSE FOR WHICH IT WAS PROVIDED AND NO RECIPIENT IS PERMITTED TO USE, COPY, OR DISCLOSE SUCH INFORMATION EXCEPT AS EXPRESSLY AUTHORIZED BY ARCTIC INDUSTRIES, LLC.

**Arctic**<sup>®</sup>  
WALK-IN COOLERS AND FREEZERS  
MIAMI, FLORIDA  
Phone: (305) 883-5581  
LOS ANGELES, CALIFORNIA  
Phone: (626) 508-0920

ETL US  
Intertek  
CONFORMS TO UL 338-071

ETL  
Intertek  
CONFORMS TO NSF 51-D

EISA