

Gas Restaurant Ranges



Model: AR36-12R

AR36-12R Gas restaurant range

STANDARD FEATURES

- Stainless steel front, galvanized sides
- Cast iron open burner, each 30,000 BTU/hr
- Thermostat (250° F- 550° F) controlled oven
- Welded frame structure for best stability
- 12" griddle plate(3/4" thickness) with splash guard
- Adjustable heavy duty legs
- 12" x12"(30x30cm) cast iron grate
- Anti-clogging pilot cover under the grate
- A pull-out crumb tray with angled handle in the front
- U shape oven burner with 31,000 BTU/hr
- Thermal coupling safety valve for the oven
- Stainless steel oven door with good insulation
- Stainless steel handle for bottom oven
- Kick plate at the bottom, easy access for servicing
- 3/4" NPT rear gas connection
- One year limited parts and labor warranty

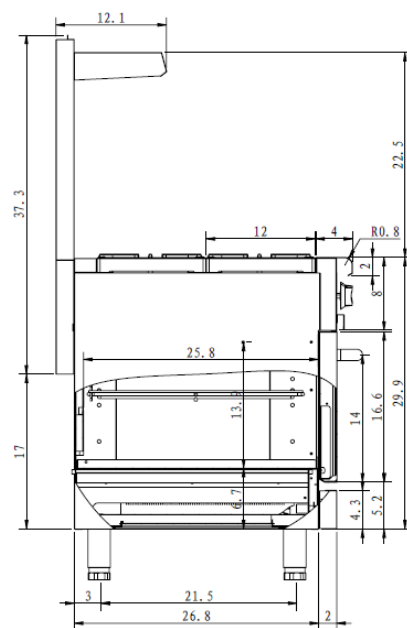
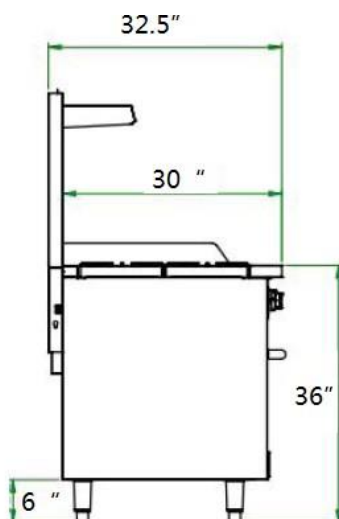
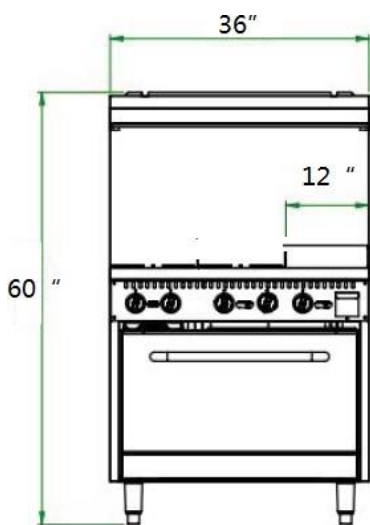

Model	Description	Total BTU/HR	Packing Size(IN)	N/W (LB)	G/W (LB)
AR36-12R	Gas range with 12" griddle& oven	171,000	41x40x52	403	507