

Gas Restaurant Ranges

AR60-10 Gas restaurant range



Model: AR60-10

STANDARD FEATURES

- Stainless steel front, galvanized sides
- Cast iron open burner, each 30,000 BTU/hr
- Thermostat (250° F- 550° F) controlled oven
- Welded frame structure for best stability
- Standby S/S pilot for easy start
- Adjustable heavy duty legs
- 12" x12"(30x30cm) cast iron grate
- Anti-clogging pilot cover under the grate
- A pull-out crumb tray with angled handle in the front
- U shape oven burner with 31,000 BTU/hr
- Thermal coupling safety valve for the oven
- Stainless steel oven door with good insulation
- Stainless steel handle for bottom oven
- Kick plate at the bottom for easy access for servicing
- 3/4" NPT rear gas connection
- One year limited parts and labor warranty

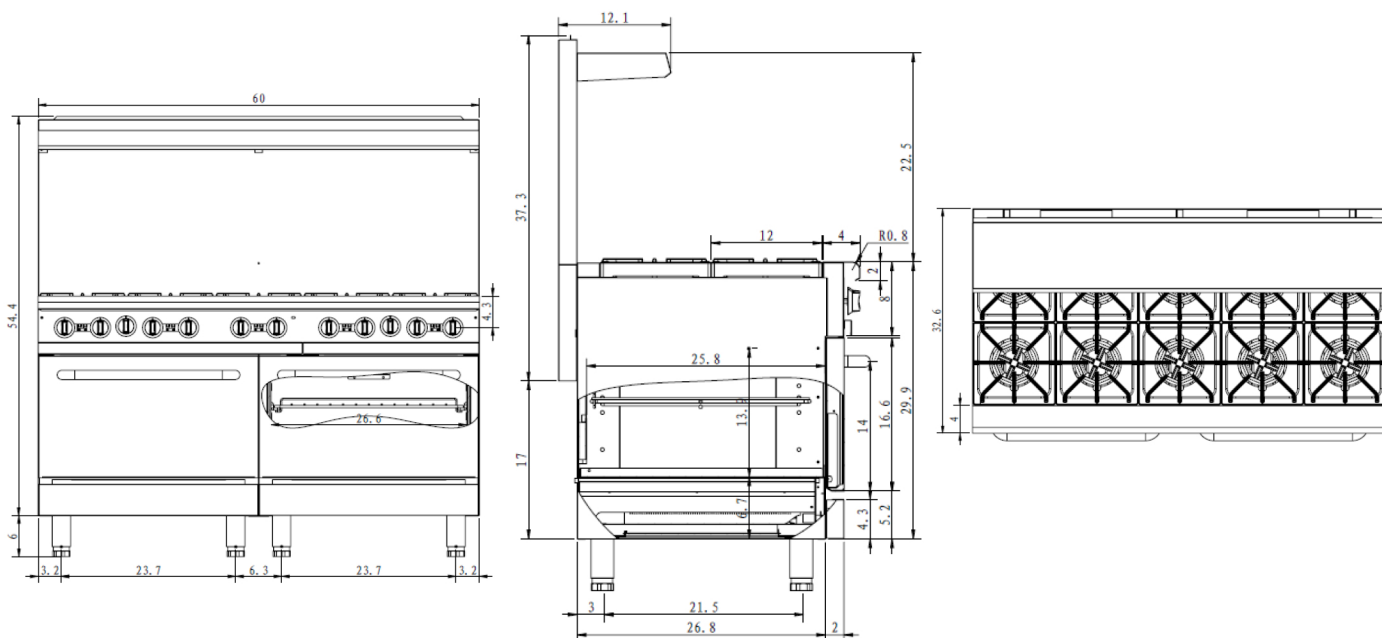

Model	Description	Total BTU/HR	Packing Size(IN)	N/W (LB)	G/W (LB)
AR60-10	Gas range with oven	362,000	65x40x44	617	739