

# Gas Restaurant Ranges



**Model AR60-24R**

ETL Safety & Sanitation Listed



AR60-24R Gas restaurant range

## STANDARD FEATURES

- Stainless steel front, galvanized sides
- (6) Cast iron open burner, each 30,000 BTU/hr
- Griddle 24" 40,000 BTU
- Thermostat (250° F- 550° F) controlled oven
- Welded frame structure for best stability
- Standby S/S pilot for easy start
- Adjustable heavy duty legs
- 12" x12"(30x30cm) cast iron grate
- Anti-clogging pilot cover under the grate
- A pull-out crumb tray with angled handle in the front
- U shape oven burner with 30,000 BTU/hr
- Thermal coupling safety valve for the oven
- Stainless steel oven door with good insulation
- Stainless steel handle for bottom oven
- Kick plate at the bottom for easy access for servicing
- 3/4" NPT rear gas connection
- One year limited parts and labor warranty

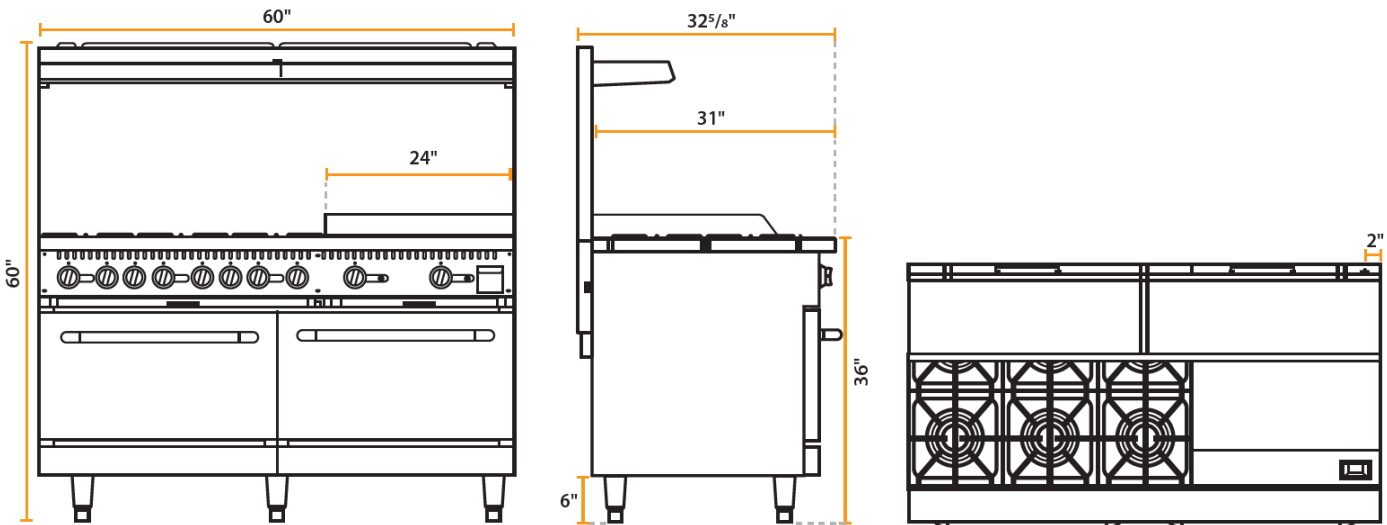

Model	Description	Oven dimension	Total BTU/HR	Packing Size(IN)	N/W (LB)	G/W (LB)
AR24r	Gas range with oven 6-Burner (2) Ovens	60"x 32.5 x60"H	280,000	28.3x40x44	617	734

[www.falconequipment.com](http://www.falconequipment.com)

879 South 4400 West

Salt Lak City, UT 84104

888-987-7894