

COOLER
(WITH FLOOR PANELS)

FREEZER
(WITH FLOOR PANELS)

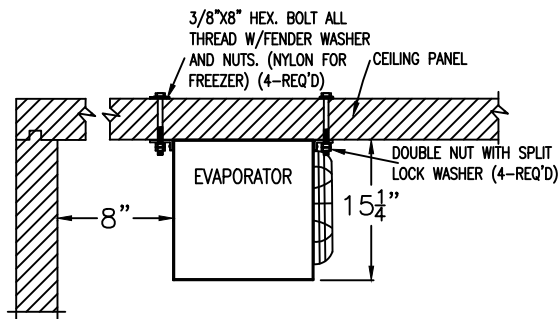

EVAPORATOR MOUNTING DETAIL
(MOUNTING HARDWARE BY OTHERS)

RIGHT HAND DOOR SHOWN
SELECT HINGE SIDE FOR DOORS

<input type="checkbox"/> COOLER	<input type="checkbox"/> FREEZER
<input type="checkbox"/> RIGHT HAND	<input type="checkbox"/> RIGHT HAND
<input type="checkbox"/> LEFT HAND	<input type="checkbox"/> LEFT HAND

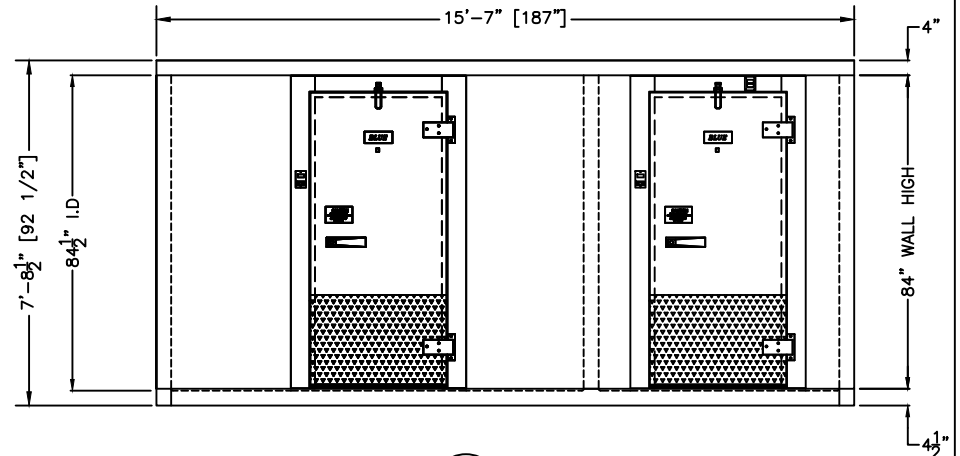

1 ELEVATION
SCALE: 1/4"=1'-0"

PRODUCT SPECIFICATIONS		
MODEL:	BL1610-COMBO-CF-R	
WALK-IN SPECIFICATIONS		
INTERIOR/EXTERIOR FINISH	26 GAUGE MILL EMBOSSED ACRYLUME OR 26 GAUGE STUCCO EMBOSSED GALVANIZED STEEL	
ELECTRICAL (VOLTS/Hz/PH)	115/60/1	
MAX AMP.	0.8 COOLER & 2.2 FREEZER	
EVAPORATOR SPECIFICATIONS	COOLER	FREEZER
ELECTRICAL (VOLTS/Hz/PH)	115/60/1	230/60/1
AMPS	20	15
WEIGHT (LBS)	47	52
CONDENSING UNIT SPECIFICATIONS	COOLER	FREEZER
ELECTRICAL (VOLTS/Hz/PH)	208-230/60/1	208-230/60/1
AMPS	15	35
WEIGHT (LBS)	195	240
FREIGHT INFORMATION (REF. INCLUDED)		
TOTAL SHIPPING WEIGHT (LBS)	3,314	
MAXIMUM PALLET SIZE	48"W X 96"L X 102"H	
NUMBERS OF PALLETS	2	

MODEL: BL1610-COMBO-CF-R
 INDOOR-WITH FLOOR
 COOLER 35°F / FREEZER -10°F
 REMOTE PRE-ASSEMBLED REFRIGERATION

CUSTOMER APPROVAL
 DATE: _____
 SIGNATURE: _____

CONFIDENTIAL
 THE DRAWINGS, TECHNICAL DATA, AND ALL OTHER INFORMATION SET FORTH IN THIS DOCUMENT COMPRISE TRADE SECRETS AND CONFIDENTIAL INFORMATION THAT IS THE EXCLUSIVE PROPERTY OF ARCTIC INDUSTRIES, LLC.
 USE OF SUCH INFORMATION IS LIMITED TO THE PURPOSE FOR WHICH IT WAS PROVIDED AND NO RECIPIENT IS PERMITTED TO USE, COPY, OR DISCLOSE SUCH INFORMATION EXCEPT AS EXPRESSLY AUTHORIZED BY ARCTIC INDUSTRIES, LLC.

Arctic
 WALK-IN COOLERS AND FREEZERS
 MIAMI, FLORIDA
 PHONE: (305) 893-5581
 LOS ANGELES, CALIFORNIA
 PHONE: (626) 508-0920
 www.arcticwalkins.com

ETL US
 Intertek
 CONFORMS TO UL 338-071

ETL
 Intertek
 CONFORMS TO NSF 51-D

EISA