

**COOLER**  
(WITH FLOOR PANELS)

**FREEZER**  
(WITH FLOOR PANELS)

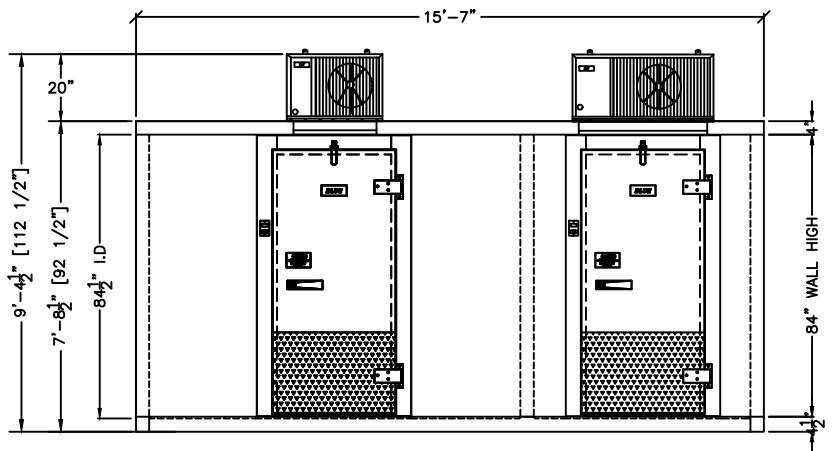

**1 ELEVATION**  
SCALE: 1/4"=1'-0"

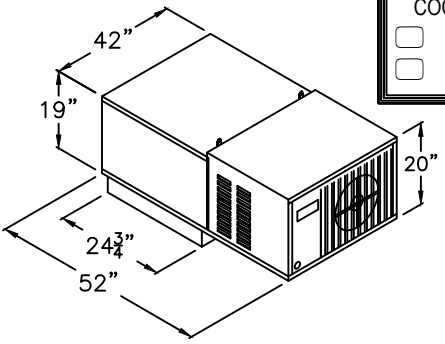
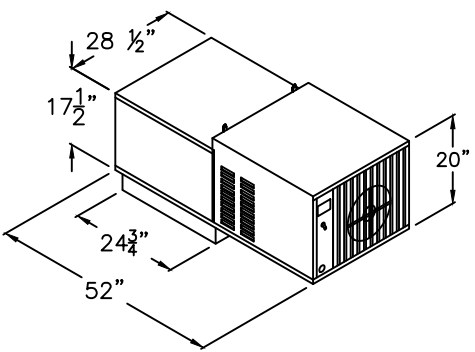

**RIGHT HAND DOOR SHOWN**  
SELECT HINGE SIDE FOR DOORS  
COOLER                      FREEZER

<input type="checkbox"/> RIGHT HAND	<input type="checkbox"/> RIGHT HAND
<input type="checkbox"/> LEFT HAND	<input type="checkbox"/> LEFT HAND

PRODUCT SPECIFICATIONS		
MODEL:	BL1610-COMBO-CF-SC	
WALK-IN SPECIFICATIONS		
INTERIOR/EXTERIOR FINISH	26 GAUGE MILL EMBOSSED ACRYLUME OR 26 GAUGE STUCCO EMBOSSED GALVANIZED STEEL	
ELECTRICAL (VOLTS/Hz/PH)	115/60/1	
MAX AMP.	0.8 COOLER & 2.2 FREEZER	
SYSTEM SPECIFICATION	COOLER	FREEZER
ELECTRICAL (VOLTS/Hz/PH)	230/60/1	230/60/1
AMPS	8.2	16.7
WEIGHT (LBS)	220	275
CORD + NEMA 6-20R PLUG		
WALK-IN AND REFRIGERATION FREIGHT		
TOTAL SHIPPING WEIGHT (LBS)	3,314	
MAXIMUM PALLET SIZE	48"W X 96"L X 102"H	
NUMBERS OF PALLETS	2	

MODEL: BL1610-COMBO-CF-SC

COOLER/FREEZER WITH FLOOR

COOLER 35°F / FREEZER -10°F

SELF-CONTAINED SYSTEM

**CUSTOMER APPROVAL**

DATE: \_\_\_\_\_

SIGNATURE: \_\_\_\_\_

**CONFIDENTIAL**

THE DRAWINGS, TECHNICAL DATA, AND ALL OTHER INFORMATION SET FORTH IN THIS DOCUMENT COMPRISE TRADE SECRETS AND CONFIDENTIAL INFORMATION THAT IS THE EXCLUSIVE PROPERTY OF ARCTIC INDUSTRIES, LLC.

USE OF SUCH INFORMATION IS LIMITED TO THE PURPOSE FOR WHICH IT WAS PROVIDED AND NO RECIPIENT IS PERMITTED TO USE, COPY, OR DISCLOSE SUCH INFORMATION EXCEPT AS EXPRESSLY AUTHORIZED BY ARCTIC INDUSTRIES, LLC.

WALK-IN COOLERS AND FREEZERS  
MIAMI, FLORIDA  
Phone: (305) 883-5581  
LOS ANGELES, CALIFORNIA  
Phone: (626) 508-0920

Intertek CONFIDENTIAL TO UL STD #17  
Intertek CONFIDENTIAL TO NSF STD #7