

COOLER
(WITH FLOOR PANELS)

FREEZER
(WITH FLOOR PANELS)

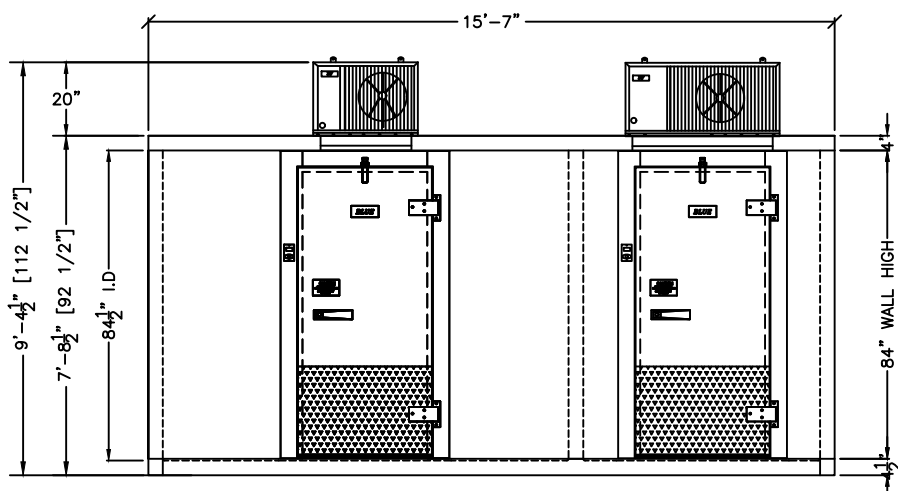

1 ELEVATION
SCALE: 1/4"=1'-0"

RIGHT HAND DOOR SHOWN
SELECT HINGE SIDE FOR DOORS
COOLER FREEZER
 RIGHT HAND RIGHT HAND
 LEFT HAND LEFT HAND

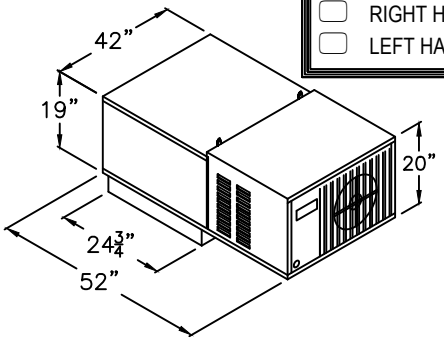
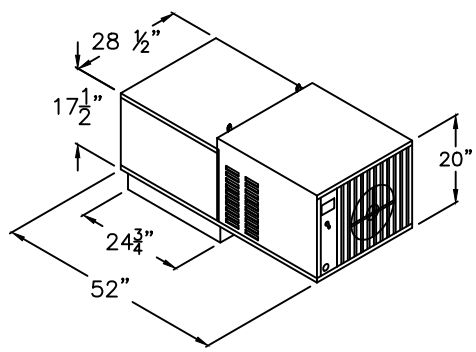

PRODUCT SPECIFICATIONS		
MODEL:	BL166-COMBO-CF-SC	
WALK-IN SPECIFICATIONS		
INTERIOR/EXTERIOR FINISH	26 GAUGE MILL EMBOSSED ACRYLUME OR 26 GAUGE STUCCO EMBOSSED GALVANIZED STEEL	
ELECTRICAL (VOLTS/Hz/PH)	115/60/1	
MAX AMP.	0.8 COOLER & 2.2 FREEZER	
SYSTEM SPECIFICATION	COOLER	FREEZER
ELECTRICAL (VOLTS/Hz/PH)	230/60/1	230/60/1
AMPS	8	16.5
WEIGHT (LBS)	215	275
CORD + NEMA 6-20R PLUG		
WALK-IN AND REFRIGERATION FREIGHT		
TOTAL SHIPPING WEIGHT (LBS)	2,553	
MAXIMUM PALLET SIZE	48"W X 96"L X 102"H	
NUMBERS OF PALLETS	2	

MODEL: BL166-COMBO-CF-SC
 COOLER/FREEZER WITH FLOOR
 COOLER 35°F / FREEZER -10°F
 SELF-CONTAINED SYSTEM

CUSTOMER APPROVAL
 DATE: _____
 SIGNATURE: _____

CONFIDENTIAL
 THE DRAWINGS, TECHNICAL DATA, AND ALL OTHER INFORMATION SET FORTH IN THIS DOCUMENT COMPRISE TRADE SECRETS AND CONFIDENTIAL INFORMATION THAT IS THE EXCLUSIVE PROPERTY OF ARCTIC INDUSTRIES, LLC.
 USE OF SUCH INFORMATION IS LIMITED TO THE PURPOSE FOR WHICH IT WAS PROVIDED AND NO RECIPIENT IS PERMITTED TO USE, COPY, OR DISCLOSE SUCH INFORMATION EXCEPT AS EXPRESSLY AUTHORIZED BY ARCTIC INDUSTRIES, LLC.

Arctic[®]
 WALK-IN COOLERS AND FREEZERS
 MIAMI, FLORIDA
 Phone: (305) 883-5581
 LOS ANGELES, CALIFORNIA
 Phone: (626) 508-0920

ETL US
 Intertek
 CONFIDENTIAL TO UL STD #1

ETL
 Intertek
 CONFIDENTIAL TO NSF STD #1

EISA