

COOLER
(WITH FLOOR PANELS)

FREEZER
(WITH FLOOR PANELS)

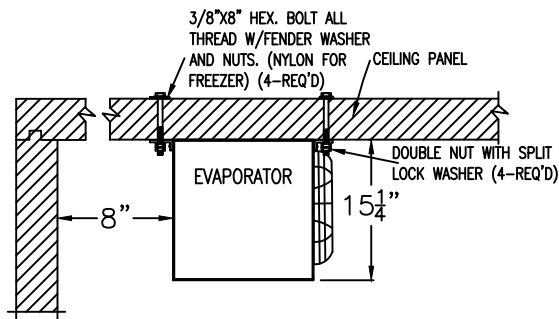

EVAPORATOR MOUNTING DETAIL
(MOUNTING HARDWARE BY OTHERS)

RIGHT HAND DOOR SHOWN
SELECT HINGE SIDE FOR DOORS

<input type="checkbox"/> COOLER RIGHT HAND	<input type="checkbox"/> FREEZER RIGHT HAND
<input type="checkbox"/> COOLER LEFT HAND	<input type="checkbox"/> FREEZER LEFT HAND

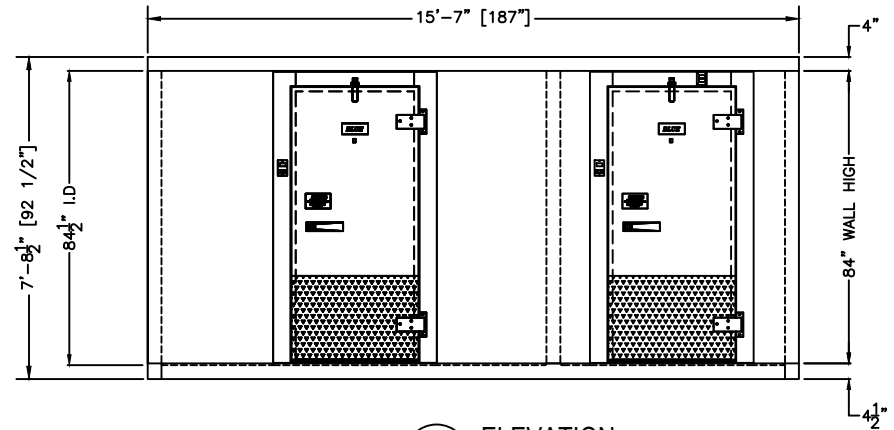

1 ELEVATION
SCALE: 1/4"=1'-0"

PRODUCT SPECIFICATIONS		
MODEL:	BL168-COMBO-CF-R	
WALK-IN SPECIFICATIONS		
INTERIOR/EXTERIOR FINISH	26 GAUGE MILL EMBOSSED ACRYLUME OR 26 GAUGE STUCCO EMBOSSED GALVANIZED STEEL	
ELECTRICAL (VOLTS/Hz/PH)	115/60/1	
MAX AMP.	0.8 COOLER & 2.2 FREEZER	
EVAPORATOR SPECIFICATIONS	COOLER	FREEZER
ELECTRICAL (VOLTS/Hz/PH)	115/60/1	230/60/1
AMPS	20	15
WEIGHT (LBS)	47	47
CONDENSING UNIT SPECIFICATIONS	COOLER	FREEZER
ELECTRICAL (VOLTS/Hz/PH)	208-230/60/1	208-230/60/1
AMPS	15	25
WEIGHT (LBS)	156	230
FREIGHT INFORMATION (REF. INCLUDED)		
TOTAL SHIPPING WEIGHT (LBS)	2,910	
MAXIMUM PALLET SIZE	48"W X 96"L X 102"H	
NUMBERS OF PALLETS	2	

MODEL: BL168-COMBO-CF-R
INDOOR-WITH FLOOR
COOLER 35°F / FREEZER -10°F
REMOTE PRE-ASSEMBLED REFRIGERATION

CUSTOMER APPROVAL

DATE: _____

SIGNATURE: _____

CONFIDENTIAL

THE DRAWINGS, TECHNICAL DATA, AND ALL OTHER INFORMATION SET FORTH IN THIS DOCUMENT COMPRISE TRADE SECRETS AND CONFIDENTIAL INFORMATION THAT IS THE EXCLUSIVE PROPERTY OF ARCTIC INDUSTRIES, LLC.

USE OF SUCH INFORMATION IS LIMITED TO THE PURPOSE FOR WHICH IT WAS PROVIDED AND NO RECIPIENT IS PERMITTED TO USE, COPY, OR DISCLOSE SUCH INFORMATION EXCEPT AS EXPRESSLY AUTHORIZED BY ARCTIC INDUSTRIES, LLC.

Arctic
WALK-IN COOLERS AND FREEZERS
MIAMI, FLORIDA
PHONE: (305) 893-5581
LOS ANGELES, CALIFORNIA
PHONE: (626) 508-0920
www.arcticwalkins.com

ETL US
Intertek
CONFORMS TO UL 308-071

ETL
Intertek
CONFORMS TO NSF 51-D7

EISA