

COOLER
(WITH FLOOR PANELS)

FREEZER
(WITH FLOOR PANELS)

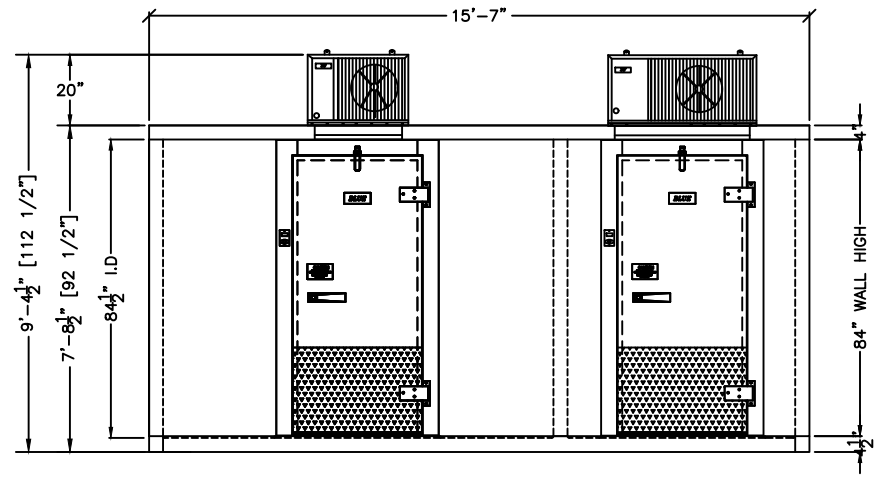

1 ELEVATION
SCALE: 1/4"=1'-0"

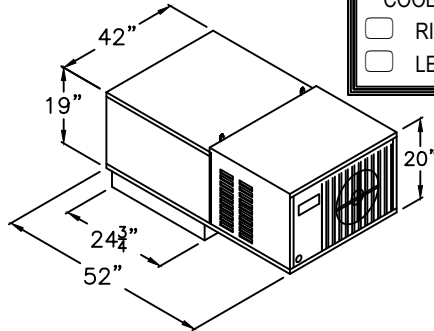
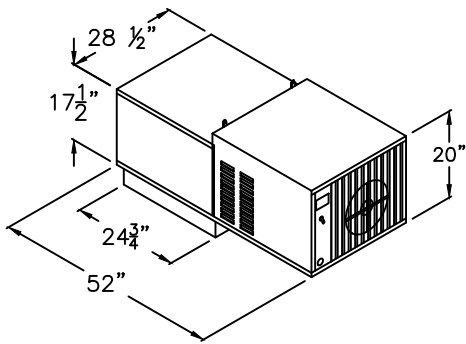

RIGHT HAND DOOR SHOWN
SELECT HINGE SIDE FOR DOORS
COOLER FREEZER
 RIGHT HAND RIGHT HAND
 LEFT HAND LEFT HAND

PRODUCT SPECIFICATIONS		
MODEL:	BL168-COMBO-CF-SC	
WALK-IN SPECIFICATIONS		
INTERIOR/EXTERIOR FINISH	26 GAUGE MILL EMBOSSED ACRYLUME OR 26 GAUGE STUCCO EMBOSSED GALVANIZED STEEL	
ELECTRICAL (VOLTS/Hz/PH)	115/60/1	
MAX AMP.	0.8 COOLER & 2.2 FREEZER	
SYSTEM SPECIFICATION	COOLER	FREEZER
ELECTRICAL (VOLTS/Hz/PH)	230/60/1	230/60/1
AMPS	8	16.5
WEIGHT (LBS)	215	275
CORD + NEMA 6-20R PLUG		
WALK-IN AND REFRIGERATION FREIGHT		
TOTAL SHIPPING WEIGHT (LBS)	2,910	
MAXIMUM PALLET SIZE	48"W X 96"L X 102"H	
NUMBERS OF PALLETS	2	

MODEL: BL168-COMBO-CF-SC

COOLER/FREEZER WITH FLOOR

COOLER 35°F / FREEZER -10°F

SELF-CONTAINED SYSTEM

CUSTOMER APPROVAL

DATE: _____

SIGNATURE: _____

CONFIDENTIAL

THE DRAWINGS, TECHNICAL DATA, AND ALL OTHER INFORMATION SET FORTH IN THIS DOCUMENT COMPRISE TRADE SECRETS AND CONFIDENTIAL INFORMATION THAT IS THE EXCLUSIVE PROPERTY OF ARCTIC INDUSTRIES, LLC.

USE OF SUCH INFORMATION IS LIMITED TO THE PURPOSE FOR WHICH IT WAS PROVIDED AND NO RECIPIENT IS PERMITTED TO USE, COPY, OR DISCLOSE SUCH INFORMATION EXCEPT AS EXPRESSLY AUTHORIZED BY ARCTIC INDUSTRIES, LLC.