



Model #AST-36

Cooling

Temperature Range	33°F - 40°F
Refrigerant	R290
Max. Ambient Temperature	90°F
Defrosting	Automatic
Temperature Controller	Digital
Horsepower	1/5

Electrical

Voltage	115
Amps	4.8
Hz	60
Phase	1
Plug Type	NEMA-5-15P
Electrical Cord Length	84"

Standard Features

- Eco-friendly R290 hydrocarbon refrigerant
- Sleek, stainless steel exterior
- Painted aluminum interior
- Top holds up to (10) 1/6 size, 6" deep food pans (sold separately)
- Full length, 8" deep cutting board, 3/4" thick
- Insulated lid helps maintain safe product temperatures
- Double self-closing swing doors with recessed handles
- 115V, 1/4 hp

Construction

Exterior Material	430 Stainless Steel
Interior Material	Painted aluminum
Insulation Material	Foamed-In-Place Polyurethane
Shelf Size	(2) 15-7/8"W x 17-1/8"D
Shelf Material	Epoxy-Coated Steel
Shelf Load Capacity	90 lbs.

Dimensions

Exterior Dimensions	36-1/4"W x 35D x 45-7/8" H
Interior Dimensions	32-1/4"W x 23-3/4"D x 23-1/2H
Overall Height (Lid Open)	51-3/4"
Cutting Board Dimensions	33-7/8"W x 8"D
Net Volume	9 cu. ft.
Net Weight	205 lbs.
Gross Weight	220 lbs.
Pan Capacity	(10) 1/6 Size



PLAN VIEW

Front View

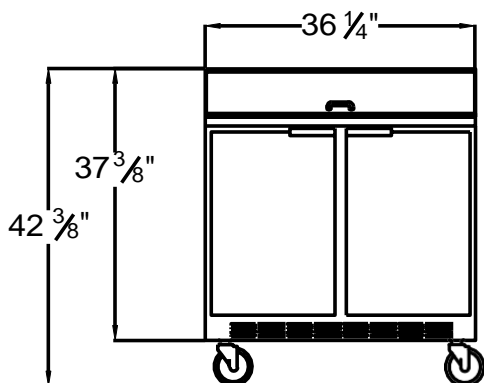

Side View

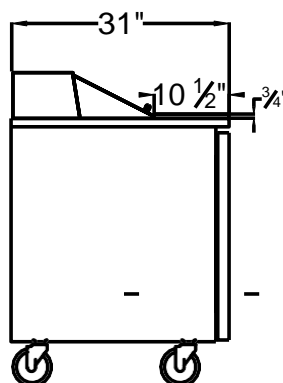

Top View

