



Model #AST-60M

Standard Features

- Eco-friendly R290 hydrocarbon refrigerant
- Sleek, stainless steel exterior
- Painted aluminum interior maintains temperatures from 33-40°F
- Top holds up to (24) 1/6 size, 6" deep food pans
- Full length, 8" deep cutting board, 3/4" thick
- Insulated lid helps maintain safe product temperatures
- Double self-closing swing doors with recessed handles
- 115V, 1/4 hp

Construction

Exterior Material	430 Stainless Steel
Interior Material	Painted aluminum
Insulation Material	Foamed-In-Place Polyurethane
Shelf Size	(2) 27-9/16"W x 17-1/16"D
Shelf Material	Epoxy-Coated Steel
Shelf Load Capacity	90 lbs.

Cooling

Temperature Range	33°F - 40°F
Refrigerant	R290
Max. Ambient Temperature	90°F
Defrosting	Automatic
Temperature Controller	Digital
Horsepower	1/4

Electrical

Voltage	115
Amps	7.8
Hz	60
Phase	1
Plug Type	NEMA-5-15P
Electrical Cord Length	84"

Dimensions

Exterior Dimensions	60-1/4"W x 35"D x 45-7/8"H
Interior Dimensions	56-1/4"W x 23-3/4"D x 23-1/2"H
Shipping Dimensions	64-1/2"W x 39-1/4"D x 49"H
Working Height	35-1/4"
Overall Height (Lid Open)	59-3/4"
Cutting Board Dimensions	60-1/8"W x 8"D x 3/4"H
Net Volume	15 cu. ft.
Net Weight	352 lbs.
Gross Weight	418 lbs.
Pan Capacity	(16) 1/6 Size



Parts & Labor



Compressor

PLAN VIEW

Front View

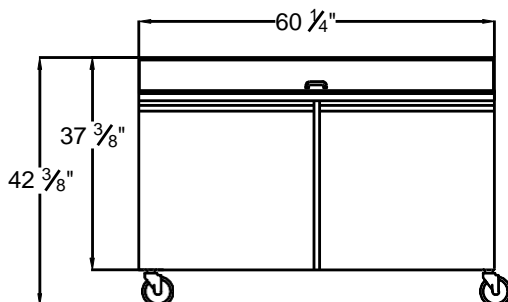

Side View

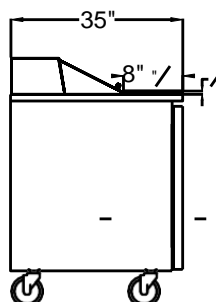

Top View

