



Model #AUC-48F

Cooling

Temperature Range	(-7)°F - 0°F
Refrigerant	R290
Max. Ambient Temperature	90°F
Defrosting	Automatic
Temperature Controller	Digital
Horsepower	1/4

Electrical

Voltage	115
Amps	3.2
Hz	60
Phase	1
Plug Type	NEMA-5-15P
Electrical Cord Length	84"

Standard Features – Undercounter Freezer Model #AUC-48F

- Environmentally-safe R290 refrigerant
- 430 series stainless steel exterior
- Painted aluminum interior
- Foamed-in-place polyurethane insulation
- One epoxy-coated shelf accommodates up to 90 lb.
- Environmentally-safe R290 refrigerant
- Temperature range of -7°F - 0°F
- Digital temperature controls
- (2) door with recessed handles
- 115V; 1/4 HP
- ETL listed. Conforms to UL STD. 471, Certified to CSA STD. C22. 2No.120
- Conforms to NSF/ANSI STD. 7

Construction

Exterior Material	430 Stainless Steel
Interior Material	Painted Aluminum
Insulation Material	Foamed-In-Place Polyurethane
Shelf	(2) 21-7/8 x 17-3/4 epoxy-coated steel holds up to 90 lb.
Casters	(4) 4" casters for mobility

Dimensions

Exterior Dimensions	47-1/4"W x 29-1/2"D x 35-1/4"H
Interior Dimensions	42-1/2"W x 22-7/8"D x 23-1/2"H
Shipping Dimensions	50"W x 32-1/4"D x 38-1/2"H
Working Height	35-1/4"
Net Volume	11.2 cu. ft.
Net Weight	256 lb.
Gross Weight	312 lb.



Parts & Labor

Compressor

PLAN VIEW

Front View

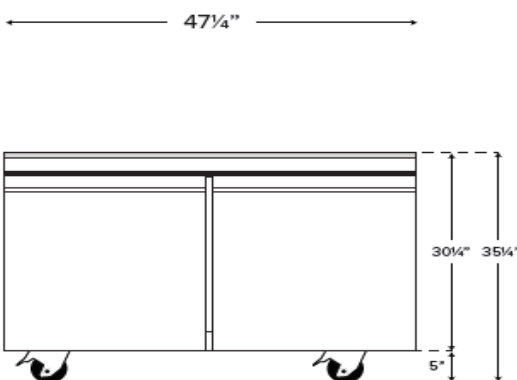

Side View

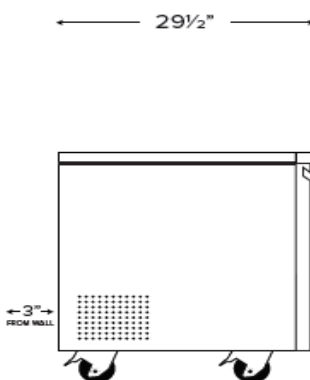

Top View

