



Model #AWT-27F

Cooling

Temperature Range	-5°F - 2°F
Refrigerant	R290
Max. Ambient Temperature	90°F
Defrosting	Automatic
Temperature Controller	Digital
Horsepower	1/5

Electrical

Voltage	115
Amps	2.1
Hz	60
Phase	1
Plug Type	NEMA-5-15P
Electrical Cord Length	84"

Standard Features – Worktop Freezer Model #AWT-27F

- Environmentally-safe R290 refrigerant
- 3-1/2" one piece backsplash built in to top
- 430 series stainless steel exterior
- Painted aluminum interior
- Foamed-in-place polyurethane insulation
- One epoxy-coated shelf accommodates up to 90 lb.
- Environmentally-safe R290 refrigerant
- Temperature range of -5°F - 2°F
- Digital temperature controls
- 115V; 1/5 HP

Construction

Exterior Material	430 Stainless Steel
Interior Material	Painted Aluminum
Insulation Material	Foamed-In-Place Polyurethane
Shelf	(1) 21-7/8 x 17-3/4 epoxy-coated steel
Casters	(4) 4" casters for mobility
Shelf Load	90 lb.

Dimensions

Exterior Dimensions	27"W x 29-1/2"D x 38-3/4"H
Interior Dimensions	22-1/4"W x 22-7/8"D x 23-1/2"H
Shipping Dimensions	29-3/4"W x 32-1/4"D x 38-1/2"H
Working Height	35-1/4"
Net Volume	5.5 cu. ft.
Net Weight	159 lb.
Gross Weight	202 lb.



Parts & Labor



Compressor

PLAN VIEW

FRONT VIEW

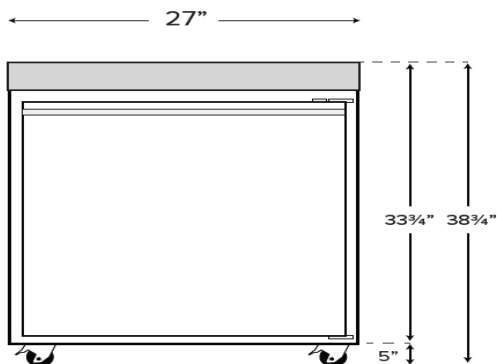

SIDE VIEW

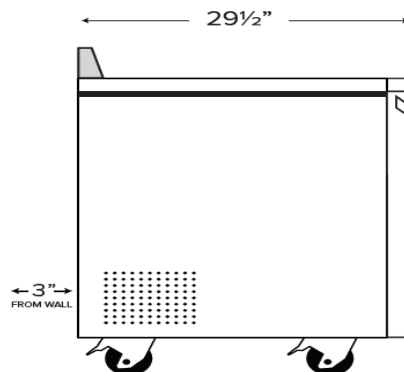

TOP VIEW

