

## AutoFill™ Water System for Hot Food Tables

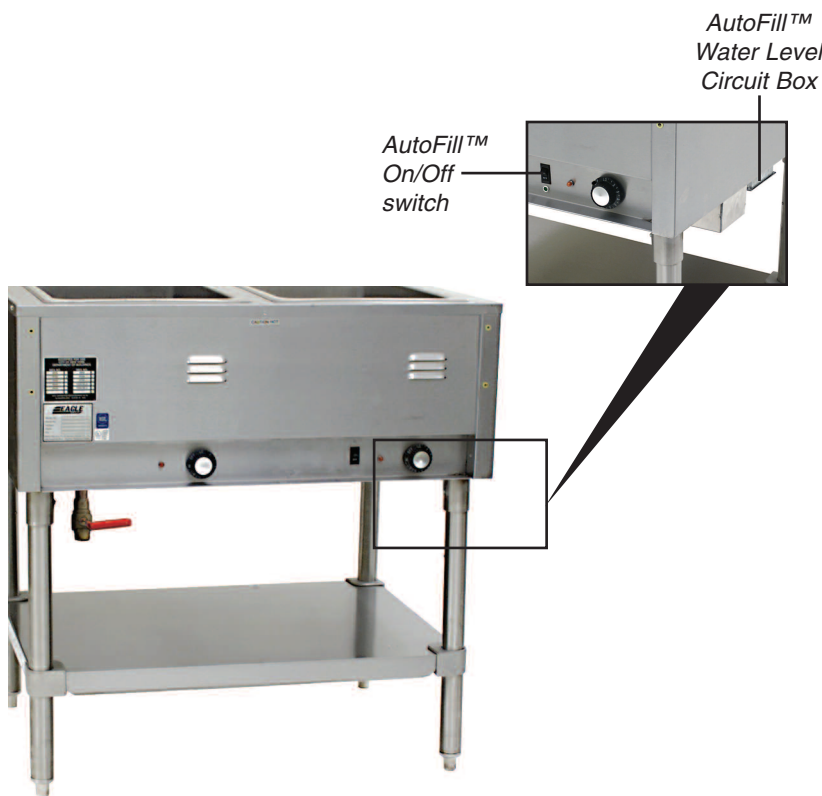

Item #:	_____
Model #:	_____
Project #:	_____
SIS #:	_____

Optional Accessories	Model #	Qty.



sealed well hot food table  
with AutoFill™ Water System

- Automatically supplies and maintains proper water level in hot food wells with drains.
- Provided with one-way check valve to prevent backflow.
- No additional holes or drains in well.
- Uses printed circuit board for fluid level detection. Does not use a float switch that could stick in the open position.
- Independent system with its own On/Off switch with LED indicator.
- Reliable level sensing (even in conditions of mineral deposit build-up).
- Maintains a 1/2" (13mm) difference in high and low water levels.
- Fluid level detection reservoir is independent of wells for ease of maintenance.

Spec sheets available for viewing, printing or downloading from our online literature library at [www.eaglegrp.com](http://www.eaglegrp.com)

# AutoFill™ Water System for Hot Food Tables

## Design & Construction Features

- Automatically supplies and maintains proper water level in each hot food well.
- Provided with one-way check valve to prevent backflow.
- Uses a printed circuit board for fluid level detection. Does not use a float switch that could stick in the open position.
- Independent system with its own On/Off switch with LED indicator.
- Reliable level sensing (even in conditions of mineral deposit build-up).
- No additional holes or drains in well.
- Fluid level detection reservoir is independent of wells for ease of maintenance.
- Maintains a ½" (13mm) difference in high and low water levels.

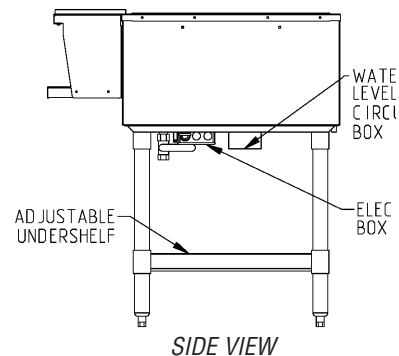
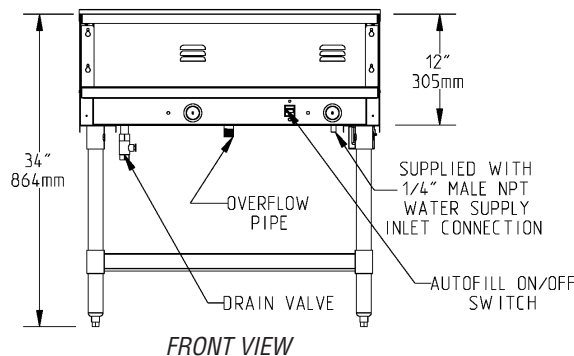
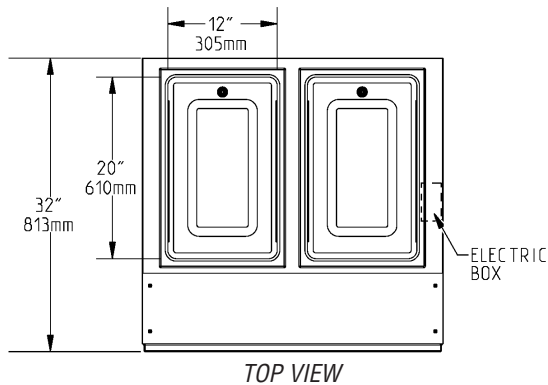

(2-well Sealed Well Hot Food Table shown. For further information on Sealed Well Hot Food Tables, see spec sheet #EG30.19)

Below is a list of products that AutoFill™ Water System applies. For further information and pricing on these products, consult your Price List. To order, add "A" in front of the first dash in model number. Example: AWT4A-LP-1

### Sealed Well Hot Food Tables

- Stationary**  
SHT2- thru 4-120  
SHT2- thru 5-240
- Portable**  
SPHT2- thru 4-120  
SPHT2- thru 5-240

### Sealed Well Hot food Gang Drop-In Units

- SGDI-1- thru 6-120T-D  
SGDI-1- thru 3-240T-D  
SGDI-1- thru 6-240T6-D

### Water Bath Steam Tables

- Electric with 2 thru 5 top openings**  
WT2- thru 5-208  
WT2- thru 5-240
- Gas with 2 thru 5 top openings**  
AWT2- thru 5-LP  
AWTP2- thru 5-LP  
AWT2- thru 5-NG  
AWTP2- thru 5-NG
- Gas with 8 top openings**  
AWT4-LP-1  
AWTP4-LP-1  
AWT4-NG-1  
AWTP4-NG-1