

# AMERICAN RANGE

Chef Inspired, Professional Cooking Equipment

## *Culinary Series* AGBU-I OVERFIRED BROILERS

### STANDARD FEATURES

- Stainless steel rugged exterior.
- 6" High Polished chrome adjustable steel legs.
- Heavy gauge welded frame construction.
- 24,000 BTU/hr. infrared burners.
- 4 burners, total BTU 96,000
- Polished glossy red knobs.
- One year limited warranty, parts and labor.

### OPTIONAL FEATURES

- Stainless steel skewer holders per deck.
- ESS-36, 36" heavy duty stainless steel stand.
- Swivel casters for stand.
- 3/4" X 36" Quick disconnect with restraining device.
- 3/4" X 48" Quick disconnect with restraining device.
- 3/4" X 60" Quick disconnect with restraining device.



GAS TYPE:  NATURAL  LP



Model Shown AGBU-I

The American Range Counter Top Infrared Overfired Broiler has a reputation that lives up to its name. The AGBU-I gas-fired powerhouse has four infrared burners that direct nearly 100,000 BTU/hr. of 1850° infrared heat downward to penetrate and sear the exposed surface of the meat, fish, vegetable or casserole products. Since the cooking is accomplished using only infrared heat, the food experiences minimal shrinkage and retains juices, tenderness and flavor.

To help tailor cooking power to the menu, the individual burner gas valves can be used to change the output power of the broiler, and the broiler grid is spring-balanced and adjustable – so raising and lowering the four position deck is easy. Extending the full width of the broiler, the removable grease tray makes clean-up a snap.

Look to American Range to provide commercial cooking performance, quality and durability - today and whenever you need to upgrade your equipment.

# Culinary Series

## AGBU-I OVERFIRED BROILERS

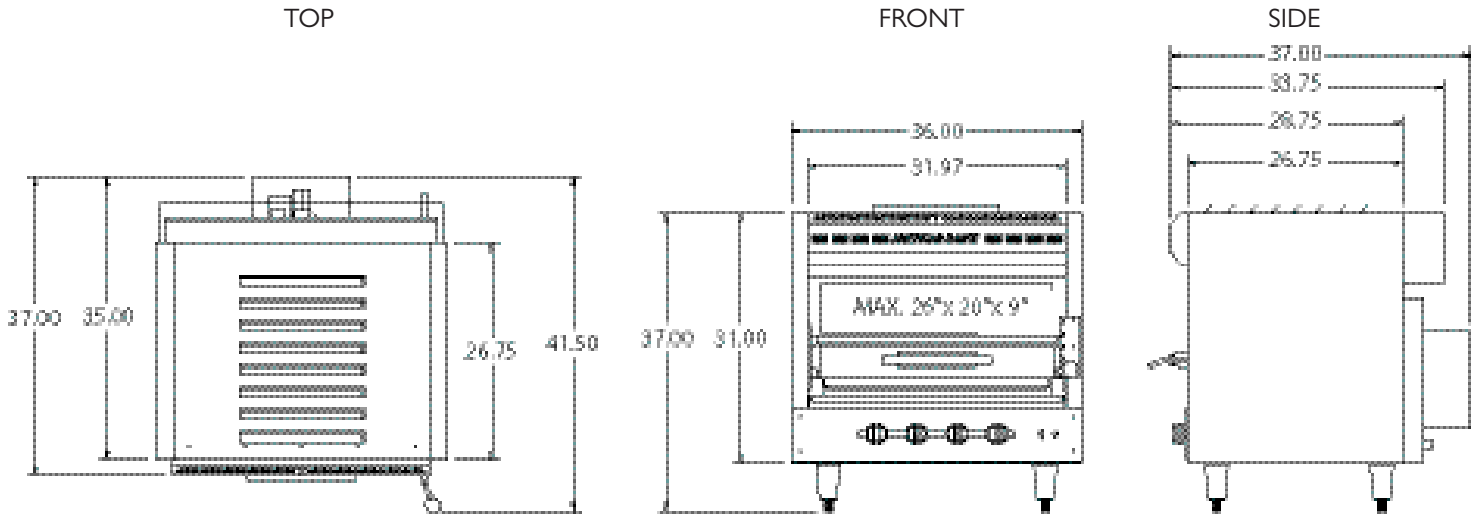

Model	Width	Depth	Height	Burners	Total BTU	KW	Shipping Weight	Lbs.	Kg.
AGBU-I	36"	33-3/4"	33"	4	96,000	23		400	182

### STANDARD FEATURES

- Stainless steel rugged exterior front, left, right.
- 6" High Polished chrome adjustable steel legs.
- Heavy gauge welded frame construction.
- 6" High stainless steel stub back in lieu of high riser.
- 24,000 BTU/hr. infrared burners, industry's highest.
- Polished glossy black knobs.
- One year limited warranty, parts and labor.

### OPTIONAL FEATURES

- Stainless steel skewer holders per deck.
- ESS-36, 36" heavy duty stainless steel stand.
- Swivel casters for stand.
- 3/4" X 36" Quick Disconnect with restraining device.
- 3/4" X 48" Quick Disconnect with restraining device.
- 3/4" X 60" Quick Disconnect with restraining device.

### GAS SUPPLY:

3/4" NPT Gas inlet. Manifold pressure is 5.0" W.C. for natural gas or 10.0" W.C. for propane gas. Specify type of gas and altitude if over 2000 feet.

### CLEARANCES:

For use only on non-combustible floors. Legs or casters are required, or 2" (51) overhang is required when curb mounted. Clearance from non-combustible walls is 0". When unit is placed next to combustible walls, clearances must exceed 12" (305) on sides, and 4" (102) from rear. Radiant broilers for non-combustible locations only.

American Range is a quality manufacturer of commercial cooking equipment. Because of continuing product improvements these specifications are subject to change without prior notice.