

AMERICAN RANGE®

A  Company

Project _____

Item # _____

Quantity _____

RAISED GRIDDLE RANGES

GAS TYPE: NATURAL LP



- AR-4B-12RG
- AR-4B-24RG
- AR-6B-24RG
- AR-4B-36RG
- AR-8B-24RG
- AR-6B-36RG

STANDARD FEATURES

- Commercial gas range 72" wide and 32 1/2" depth.
- Cooking height 36" and 44".
- Stainless steel sides, front and 6" deep front landing ledge.
- Adjustable steel legs (casters optional).
- Choose: 6" high stainless-steel stub back, high riser or high riser with shelf at no charge.
- Two year limited warranty, parts and labor.
- Base options: Standard, convection, innovection or storage base.

OPEN BURNERS

- 12" x 12" cast-iron top grates.
- 32,000 BTU/hr lift-off open burners.
- Removable full width drip pan under burner.

STANDARD OVEN *(Two Standard 26 1/2" Ovens)*

- Steel oven burner rated at 35,000 BTU/hr.
- Oven dimensions: 26 1/2"W x 22 1/2"D x 13 1/2"H.
- Thermostat ranging from 250°F to 500°F (121°C to 260°C).
- Oven Door: Spring assisted, counterweight door.
- Two chrome plated oven racks (additional racks optional).
- Two fixed rack positions.
- Porcelain enamel oven interior for easy cleaning.
- 100% safety gas shut off.

CONVECTION OVEN *(In place of standard oven)*

- Steel oven burner rated at 30,000 BTU/hr.
- Convection oven fan improves heat transfer for a faster cook time.
- Thermostat ranging from 250°F to 500°F (121°C to 260°C).
- Two chrome plated oven racks (additional racks optional).
- Chrome rack guides with five tray positions.

INNOVECTION® OVEN *(In place of standard oven)*

- Steel oven burner rated at 30,000 BTU/hr.
- Thermostat ranging from 250°F to 500°F (121°C to 260°C).
- Two chrome plated oven racks (additional racks optional).
- Two fixed rack positions.
- The low speed blower motor circulates heat to provide a uniform heating pattern.
- Great for baked goods.

RAISED GRIDDLES

- 1" thick steel griddle plate.
- 3" wide grease collector.
- One burner every 12", rated at 20,000 BTU/hr.
- Stainless steel pilot for each burner for automatic ignition.
- Manual control valve for each burner.

AVAILABLE OPTIONS

- Swivel Casters (set of four – two with front brakes).
- Storage Cabinet Base. *(In place of standard oven).*



Model AR-4B-36RG

Shown with optional casters.

DESCRIPTION

American Range, restaurant range size 72" x 32-1/2" x 56"
Stainless steel front, sides, backriser, shelf and 6" adjustable legs. Removable full width drip pan. Choose a combo 32,000 BTU/hr. open burners with no-clog lift-off burner heads along with 20,000 BTU/hr. per 12" section raised griddle. Heavy-duty cast iron grates, 12" x 12". Burner knobs are cool to the touch, high temperature material. Two ovens: 35,000 BTU/hr. standard oven, 30,000 BTU/hr. for convection or innovection with porcelain interior and inside door panel, oven interior measures 26-1/2"W x 22-1/2"D x 13-1/2"H. Oven thermostat adjusts from 250°F to 500°F. All ovens supplied with two racks. Oven door with a spring assisted, counterweight mechanism requiring no adjustment. Rear gas connection and pressure regulator.



DESIGNED & BUILT IN USA
PROFESSIONAL COOKING EQUIPMENT

AMERICAN RANGE®

A  Company

13592 Desmond St Pacoima CA 91331

T. 818.897.0808 F. 818.897.1670

Toll Free: 888.753.9898

www.AmericanRange.com

A????? RevA 03152023

RAISED GRIDDLE RANGES

TOP	MODEL	BTU	Shipping Weight*	
			(KW)	LBS (KG)
	AR-4B-12RG	183,000	(54)	425 (193)
	AR-4B-12RG-NV	178,000	(51)	505 (229)
	AR-4B-12RG-C	178,000	(51)	505 (229)
	AR-4B-12RG-SB	148,000	(44)	355 (161)
	AR-4B-24RG	222,000	(65)	630 (286)
	AR-4B-24RG-126L-SBR	203,000	(60)	590 (268)
	AR-4B-24RG-NVL-SBR	195,000	(57)	710 (322)
	AR-4B-24RG-CL-SBR	198,000	(58)	590 (268)
	AR-4B-24RG-NN	222,000	(65)	560 (254)
	AR-4B-24RG-DSB	168,000	(49)	490 (222)
	AR-6B-24RG	302,000	(89)	795 (361)
	AR-6B-24RG-NVL-126R	294,000	(87)	835 (379)
	AR-6B-24RG-NVL-SBR	259,000	(76)	750 (340)
	AR-6B-24RG-NN	286,000	(84)	875 (397)
	AR-6B-24RG-CL-126R	297,000	(87)	835 (379)
	AR-6B-24RG-CL-SBR	262,000	(77)	750 (340)
	AR-6B-24RG-CC	292,000	(86)	875 (397)
	AR-6B-24RG-126L-SBR	267,000	(79)	710 (322)
	AR-6B-24RG-DSB	232,000	(68)	625 (283)
		AR-4B-36RG	258,000	(76)
AR-4B-36RG-NVL-126R		250,000	(74)	850 (385)
AR-4B-36RG-NVL-SBR		215,000	(63)	765 (347)
AR-4B-36RG-NN		242,000	(71)	890 (404)
AR-4B-36RG-CL-126R		253,000	(74)	850 (385)
AR-4B-36RG-CL-SBR		218,000	(64)	765 (347)
AR-4B-36RG-CC		248,000	(72)	890 (404)
AR-4B-36RG-126L-SBR		223,000	(66)	725 (329)
AR-4B-36RG-DSB		188,000	(55)	640 (290)
		AR-8B-24RG	366,000	(107)
	AR-8B-24RG-NVL-126R	358,000	(105)	880 (399)
	AR-8B-24RG-NVL-SBR	323,000	(95)	795 (361)
	AR-8B-24RG-NN	350,000	(103)	920 (417)
	AR-8B-24RG-CL-126R	361,000	(106)	880 (399)
	AR-8B-24RG-CL-SBR	326,000	(96)	795 (361)
	AR-8B-24RG-CC	356,000	(104)	920 (417)
	AR-8B-24RG-126L-SBR	331,000	(97)	830 (376)
	AR-6B-36RG	322,000	(95)	855 (388)
	AR-6B-36RG-NVL-126R	314,000	(92)	895 (406)
	AR-6B-36RG-NVL-SBR	279,000	(82)	810 (368)
	AR-6B-36RG-NN	306,000	(90)	935 (424)
	AR-6B-36RG-CL-126R	317,000	(93)	895 (406)
	AR-6B-36RG-CL-SBR	282,000	(83)	810 (368)
	AR-6B-36RG-CC	312,000	(92)	935 (424)
	AR-6B-36RG-126L-SBR	287,000	(84)	845 (383)
AR-6B-36RG-DSB	252,000	(74)	760 (345)	

“C” = Convection Oven, “NV” = Innovection Oven, “SB” = Storage Base, “RG” = Raised Griddle Top.
Raised Griddle on the right, storage base on the right.

Combo base options available – choose standard, convection or innovection ovens or storage base, contact the factory.

CONVECTION OVEN ELECTRICAL		
VOLTAGE	PHASE	AMPS
120	1	4

INNOVECTION OVEN ELECTRICAL		
VOLTAGE	PHASE	AMPS
120	1	1

MANIFOLD PRESSURE		
NATURAL GAS	PROPANE GAS	MANIFOLD SIZE
5.0" W.C.	10.0" W.C.	3/4" (19MM)

NMFCODE: 25970-2 Class: 85

*Shipping weight includes packaging and is approximate.

15 amps three prong cord provided

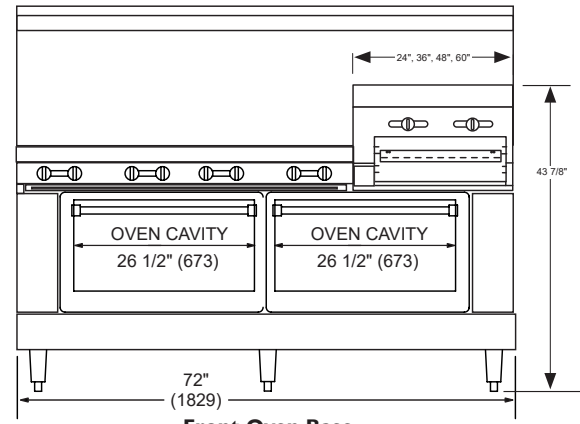

Front Oven Base

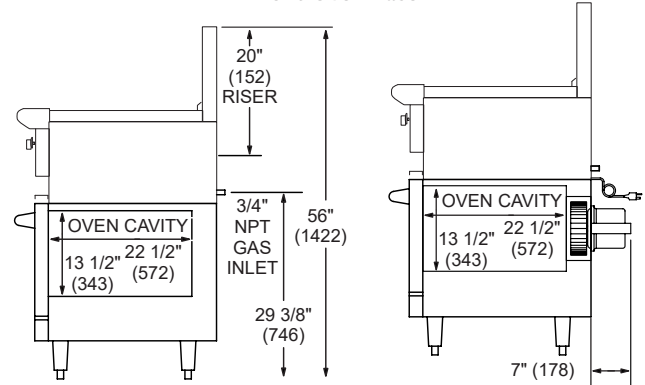

Side Standard Oven

Side Convection Oven

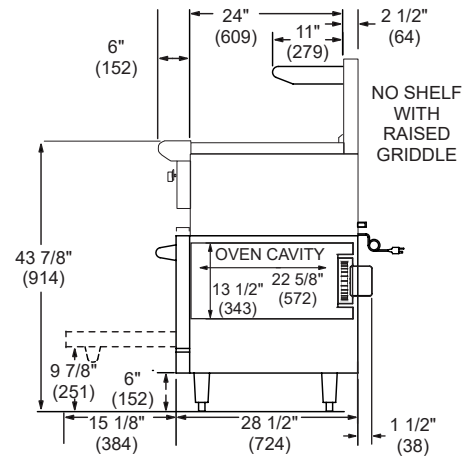

Side Innovection® Oven

Specify type of gas and altitude if over 2000 feet.

Please specify gas type when ordering.
 COMBUSTIBLE WALL CLEARANCES:

For use only on non-combustible floors. Legs or casters are required, or 2" (51) overhang is required when curb mounted. Clearance from non-combustible walls is 0". When unit is placed next to combustible walls, clearances must exceed 12" (305) from sides, and 4" (102) from rear.

Commercial cooking equipment requires an adequate ventilation system. For additional information, refer to the National Fire Protection Association's standard.

NFPA96 "Vapor Removal from Cooking Equipment." (NOTE: For North America only)



AMERICAN RANGE

A **Hotco** Company

13592 Desmond St Pacoima CA 91331
 T. 818.897.0808 F. 818.897.1670

Toll Free: 888.753.9898

www.AmericanRange.com

A???? RevA 03152023