

AMERICAN RANGE

QUALITY COMMERCIAL COOKING EQUIPMENT

ARMG-OB/ARTG-OB COMBINATION GRIDDLES & OPEN BURNERS

GRIDDLES WITH OPEN BURNERS

- Available with manual or thermostatic controls
- Highly polished steel griddle plate
- "U" shaped burners for every 12" of griddle surface
- Stainless steel pilots for instant ignition on each burner
- 3" wide S/S grease trough and a large grease pan
- 32,000 BTU each lift off open burners for easy cleaning
- 21" deep cooking service.
- Optional Saute and Wok burner heads
- S/S Wok Ring Ring available.
- Limited one year parts and labor warranty



Shown: Thermostatic Griddle
Model AR36-24TG2OB



American Range ARMG-OB/ARTG-OB series griddles are designed to provide the ultimate in performance and durability. As with all of our heavy duty countertop equipment, they are built to the highest commercial standards to ensure years of trouble free service, featuring superior frame construction and stainless steel exterior for easy maintenance. Combine all of this and our affordable prices and you have the best value for your budget.

ARMG GRIDDLES & OPEN BURNERS

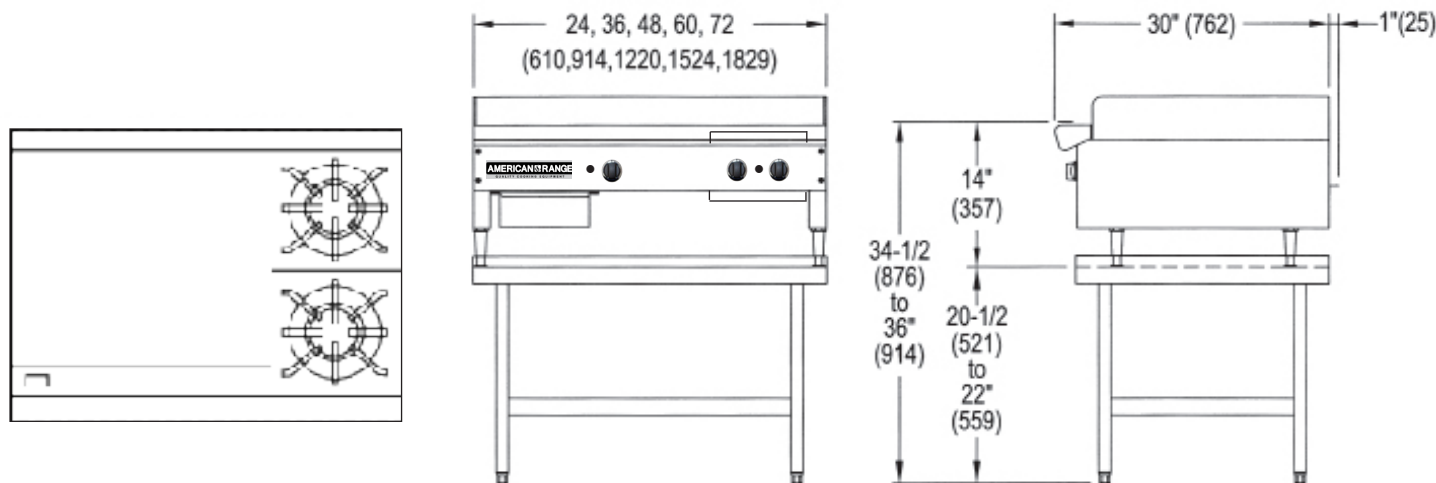

Shown with optional 4" legs

MANUAL		THERMOSTATIC		GRIDDLES WITH BURNERS						S/S STANDS		
Model	Model	Width	Depth	Height	Griddle Burners	Total BTU	KW	Ship Wt. Lbs.	Kg.	Model	Lbs.	Kg.
AR24-12G2OB	AR24-12TG2OB	24"	30"	10-1/2"	1	94,000	27	360	163	•ESS-24	47	21
AR36-24G2OB	AR36-24TG2OB	36"	30"	10-1/2"	2	124,000	36	437	198	•ESS-36	54	25
AR48-36G2OB	AR48-36TG2OB	48"	30"	10-1/2"	3	154,000	45	527	239	•ESS-48	72	33
AR60-48G2OB	AR60-48TG2OB	60"	30"	10-1/2"	4	184,000	53	787	356	•ESS-60	99	45
AR72-60G2OB	AR72-60TG2OB	72"	30"	10-1/2"	5	214,000	62	954	432	•ESS-72	110	50
AR84-72G2OB	AR84-72TG2OB	84"	30"	10-1/2"	6	244,000	71	1137	515	•ESS-84	125	77

• **2OB** refers to 2 burners. For 4 burners change **2OB** to **4OB**, & add 12" to overall width.

• 4" legs set of 4. 60", 72" & 84" models require set of 6 legs.

For Reverse configuration call factory for pricing.

CRATED DEMENSIONS: Height 20" (508) x Depth 36" (914) x Width add 5" (127) to width.

• Casters for stands (set of 4) A35104

• Casters for stands (set of 6) A35105

STANDARD FEATURES

- Highly polished steel griddle plate, 3/4" (19) thick
- 21" Deep cooking surface
- Easy cleaning, removable cast iron two-piece burner heads, all low high gas output of 32,000 BTU/hr, highest in the industry
- 3" wide S/S grease trough and a large grease pan
- Stainless steel pilots for ignition on each burner
- Limited one year parts and labor warranty

OPTIONAL FEATURES

- 4" (102) adjustable legs
- Equipment stand.
- Casters for stands
- Partial grooving
- Open burner combinations
- Saute and wok burner heads (open burner)
- Stainless steel wok ring (open burner)
- 1" (25.4) thick plate available

GAS SUPPLY: 3/4" NPT Gas inlet. Manifold pressure is 5.0"W.C. for natural gas or 10.0"W.C. for propane gas. Specify type of gas and altitude if over 2000 feet.

CLEARANCES: For use only on non-combustible floors. Legs or casters are required, or 2" (51) overhang is required when curb mounted. Clearance from non-combustible walls is 0". When unit is placed next to combustible walls, clearances must exceed 12" (305) on sides, and 4" (102) from rear. Radiant broilers for non-combustible locations only.

American Range is a quality manufacturer of commercial cooking equipment. Because of continuing product improvements these specifications are subject to change without prior notice.