

AMERICAN RANGE

Chef Inspired, Professional Cooking Equipment

Culinary Series

AVB VERTICAL BROILERS

STANDARD FEATURES

- Heavy gauge steel frame instruction.
- All stainless steel front, side and top.
- Compact design for counter installation.
- Sturdy skewers hold up to 80 Lbs of product.
- 15" diameter pan at the bottom, slide adjustment front to back.
- High efficiency infrared burners rated at **Power-Plus** 20,000 BTU/hr each
- Manual valve control for each burner.
- Heavy duty powerful gear motor for smooth and even rotation.
- Front panel located toggle on/off switch.
- Six position adjustment of skewer.
- Two year limited warranty, parts and labor.

GAS TYPE: NATURAL LP



Model AVB-2E
Power-Plus
20,000 BTU/hr Burners

The Culinary Series by American Range, these hand-crafted broilers are engineered with the most advanced features and fabricated to ensure a long, demanding life. All welded frame construction and heavy gauge stainless steel panels ensure long life and exceptional quality; an all stainless steel body makes clean up easy.

High efficiency atmospheric infrared burners provide maximum performance at the least possible cost. With four models to choose from, you can select the one most suited to your needs.

Quality, dependability and customer satisfaction make American Range the brand of choice among professional chefs and restaurateurs worldwide.

www.AmericanRange.com



Culinary Series AVB VERTICAL BROILERS

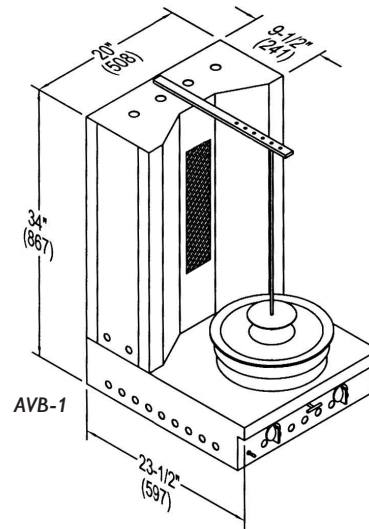
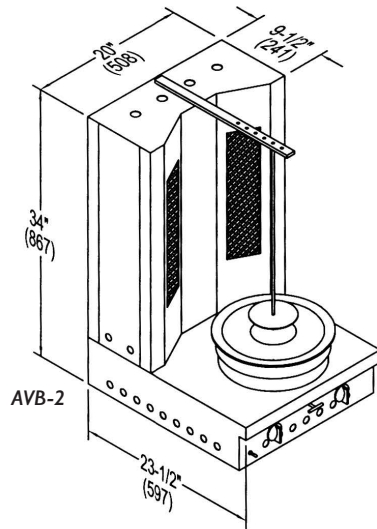
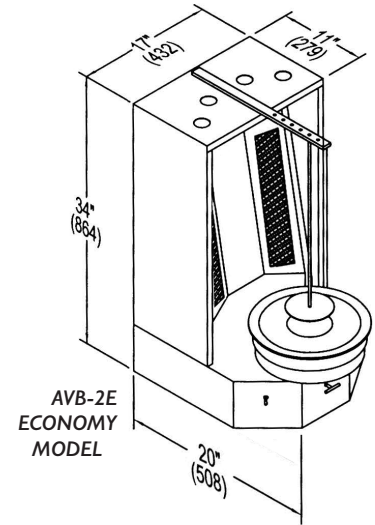
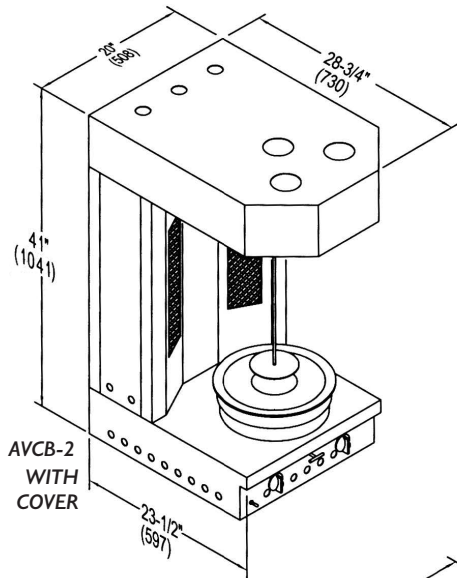

OPTIONAL S/S STANDS

Model	Ship Weight	
	Lbs	(kg)
VES-17	39	(18)
VES-20	39	(18)

AVB VERTICAL BROILERS

Model	Description	Dimensions Width x Depth x Height (mm)	Total BTU	(kW)	Ship Weight		Crated Dimension Width x Depth x Height (mm)
					Lbs	(kg)	
AVB-2E	17" Wide AVB Vertical Broilers	17" W x 23½" D x 34" H (432 x 597 x 864)	40,000	(12)	100	(45)	22"W x 28½"D x 42"H (559 x 724 x 1067)
AVB-1	20" Wide AVB Vertical Broilers	20" W x 23½" D x 34" H (508 x 597 x 864)	20,000	(6)	100	(45)	25"W x 28½"D x 42"H (635 x 724 x 1067)
AVB-2	20" Wide AVB Vertical Broilers	20" W x 23½" D x 34" H (508 x 597 x 864)	40,000	(12)	125	(57)	25"W x 28½"D x 42"H (635 x 724 x 1067)
AVCB-2	20" Wide AVB Covered Vertical Broilers	20" W x 23½" D x 41" H (508 x 597 x 1041)	40,000	(12)	150	(68)	25"W x 28½"D x 42"H (635 x 724 x 1067)

GAS SUPPLY AND ELECTRICAL INFORMATION

- A gas pressure regulator is provided and must be installed when the appliance is connected to the gas supply.
- 120 VAC, Single Phase, 60Hz, .6 amp. 3 prong grounded power cord provided.

GAS SUPPLY:

¾" NPT Gas inlet. Manifold pressure is 5.0" W.C. for natural gas or 10.0" W.C. for propane gas. Specify type of gas and altitude if over 2000 feet.

CLEARANCES:

For use only on non-combustible floors. Legs or casters are required, or 2" (51) overhang is required when curb mounted. Clearance from non-combustible walls is 0". When unit is placed next to combustible walls, clearances must exceed 12" (305) on sides, and 4" (102) from rear. Radiant broilers for non-combustible locations only.

American Range is a quality manufacturer of commercial cooking equipment. Because of continuing product improvements these specifications are subject to change without prior notice.