



Avenger® LT

Project _____
 Item _____
 Quantity _____
 CSI Section 11400 _____
 Approval _____
 Date _____

Avenger® LT

Models

Avenger® LT



Standard Features

- Automatic fill
- Push button start
- Labyrinth type door design
- Automatic pumped drain for floor and wall drain installations
- Recirculating wash and rinse
- Stainless steel wash/rinse pump
- Universal Timer
- Manual override for extended wash and deliming
- Simplified controls allow easy access for operation and service
- Door switch
- Low product indicator light
- One (1) each peg and combination rack included
- Above water scrap basket
- Built-in chemical pumps and priming switches

Options

- Scale Prevention System (SPS)
- Replacement cartridges for SPS (2-pack)
- Water Hammer Arrestor
- Back Panel
- Tie Down

Accessories

- 36-Compartment Rack
 - 4-1/8" tall (105 mm)
 - 5-5/8" tall (143 mm)
 - 7" tall (178 mm)
- Combination Rack
- Peg Rack
- Machine Stand
 - 6" (152 mm) high
 - 18" (457 mm) high

Specifications

- Uses 1.2 gallons (4.5 liters) of water per rack
- Uses 28.8 gallons (109 liters) of water per hour
- Cleans 24 racks per hour
- Two-minute automatic cycle
- Powerful 3/4 hp wash pump motor
- Air insulated between body and stainless steel housing
- 304 stainless steel construction
- Low product indicator light alerts operator when detergent and sanitizer are low

Notes:

A vent hood is not recommended above the Jackson Avenger® LT as it does not produce excessive vapors. *Always check with the local building code to know what type of ventilation is required for commercial dish machine installations in your area.*

Normal operation of the Avenger LT® generates steam that may escape from the door. Materials such as wood laminate, veneers, etc. are unsuitable for use in areas exposed to dishwasher steam and detergents. Stainless steel or other moisture-resistant shields are recommended for surfaces adjacent to Avenger LT® sides and top.



Intertek





Avenger® LT

LEGEND:

- A - Water Inlet - 1/2" Female Pipe Thread, 2 1/2" AFF (Connect to a true 1/2" ID water line)
 - B - Electrical Connection
 - C - Drain Connection - 6' coiled drain hose. Shipped inside machine. Must be installed no more than 24" AFF.
- All dimensions from floor can be increased 1" with adjustable feet supplied.

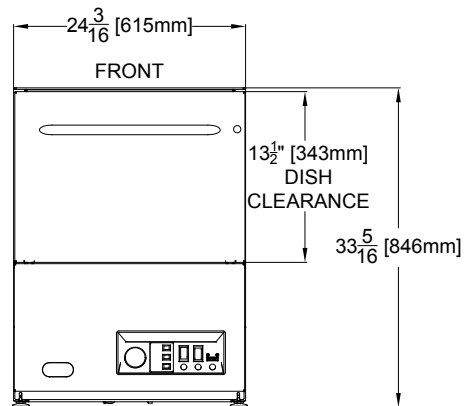
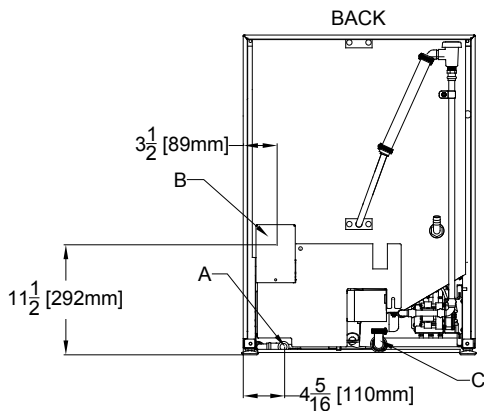
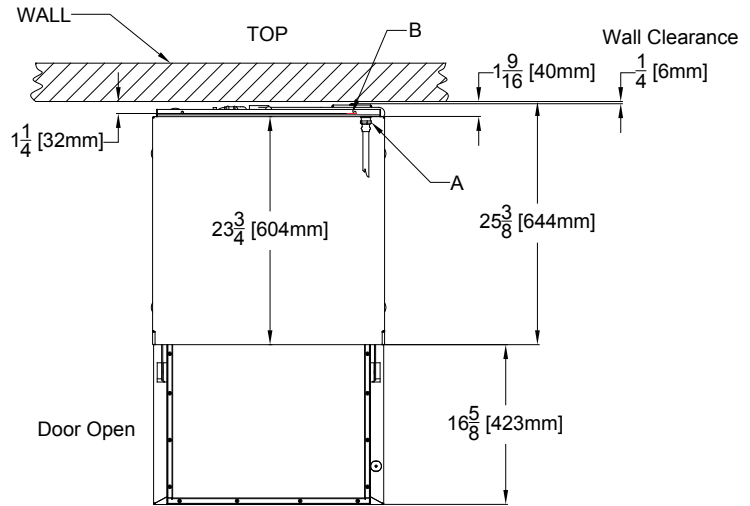

MODEL NO.	MACHINE DIMENSIONS				WALL CLEARANCE	SHIPPING INFORMATION					
	INSIDE CLEARANCE HEIGHT	INSIDE CLEARANCE WIDTH	INSIDE CLEARANCE DEPTH	DOOR OPEN DEPTH		WEIGHT	CLASS	CUBE	HEIGHT	WIDTH	DEPTH
Avenger® LT	13-1/2" (343 mm)	20" (508 mm)	20" (508 mm)	42" (1067 mm)	1/4" (6 mm)	248 lbs (112 kg)	92.5	23.3 cu. ft.	42" (1067 mm)	33" (838 mm)	29" (737 mm)

APPROXIMATE TOTAL AMP LOADS	
115/60/1	13.2

OPERATING CAPACITY	
Racks per Hour	24
Dishes per Hour	600
Glasses per Hour	864

WASH PUMP MOTOR	
Wash Pump	3/4 hp

OPERATING CYCLE	
Wash Cycle (seconds)	56
Drain Time (seconds)	29
Rinse Cycle (seconds)	35
Total Cycle (seconds)	120

WATER REQUIREMENTS	
Gallons per Rack	1.2 gal (4.5 L)
Gallons per Hour	28.8 gal (109 L)
Flow Pressure (PSI)	15 - 25
Waterline Size (IPS)	1/2"
Drainline Size (OD)	1-3/8"

OPERATING TEMPERATURES	
Wash	140° F (60° C)
Rinse	140° F (60° C)

HOW TO SPECIFY: Avenger® LT

Jackson WWS, Inc.
 Shipping Address: 6209 North U.S. Highway 25E, Gray, KY 40734
 Mailing Address: P.O.Box 1060, Barbourville, KY 40906
 Telephone: 888-800-5672 • Fax: 606-523-1799
 Email: info@jacksonwws.com
 07610-003-34-04 [09/24/15]

www.jacksonwws.com

We reserve the right to change specifications in this bulletin without incurring any obligation for equipment previously or subsequently sold.