

Model B-DGP

PRECISIONBREW™ Dual Thermal Gravity Container Brewer



Model B-DGP

(Containers sold separately)

Digitally controlled gravity container brewer holds brew temperature to $\pm 1^{\circ}\text{F}$ throughout brew cycle. Brew temperature, brew volume, operator defined pre-infusion/pulse brewing, and low temp/no brew are programmable from the front display.



GRINDMASTER™
CORPORATION



Model B-DGP

Features

- Model B-DGP is a twin, digitally controlled brewer. It brews into 2.5L (85oz.) vacuum insulated gravity containers (Containers sold separately).
- Vacuum insulated gravity container model GP-2.5 is portable and holds fresh coffee for hours without adding heat.
- High productivity - 6,000 watts of heating capacity.
- Precise Brew Temperature - The brewer will hold the brew temperature to +/- 1°F during the complete brew cycle.
- Brew Volume - Can be set by 'teach' mode to eliminate trial-and-error set-up.
- Pulse brewing/pre-infusion - Allows brew sequence to extract up to 20% more dissolved solids per batch of coffee. Programmable: number of pulses, pulse-on time and pulse-off time. Changing the pulse sequence does not affect the brew volume.
- Low Temp/No Brew - Allows the brew cycle to begin only when the water has reached the optimum brew temperature.
- Cycle Counter - The brewer counts the total number of brew cycles.
- Programming Lock-Out - The brewer settings can be "locked" to prevent tampering.
- Gourmet Brew basket, (pn 71431) available as an option.
- Warranty - 2 years parts and labor on the brewer. 4 years part warranty on the control board.

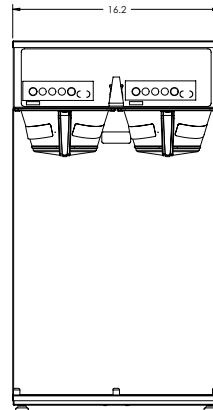

FRONT VIEW

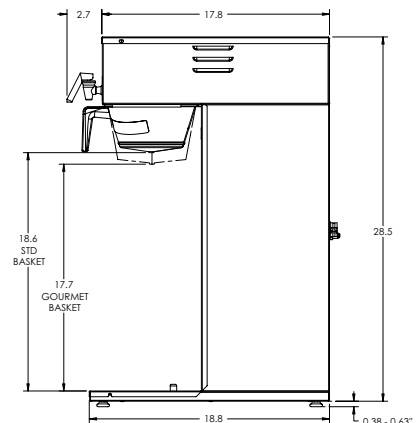

SIDE VIEW

Specification	Model B-DGP
Electrical	120/240V, 6000W, 25A 120/208V, 4492W, 21.6A <i>European voltages available</i>
Brew Capacity (# of 2.5 liter containers / hour)	@ 240V: 26 @ 208V: 20
Water Line	1/4" Flare
Water Line Pressure	30 to 80 psi
Tank Drain	Yes
Tank Size	4.3 Gallons
Dimensions (H x W x D)	29" H x 16-1/4" W x 17-3/4"D (73 cm x 41 cm x 45 cm)
Ship Dimensions (H x W x D)	32" H x 21" W x 24"D (81 cm x 53 cm x 61 cm)
Weight	46 lbs (21 kg)
Ship Weight	55 lbs (25 kg)
Listings	UL, CUL, NSF, (CE for E models only)

Specifications are subject to improvement or change without notice.



GRINDMASTER™
CORPORATION



Grindmaster® Coffee Grinders and Brewers • Espresso® Espresso Machines • Crathco® Hot Beverage Dispensers
Crathco® Cold and Frozen Beverage Dispensers • American Metal Ware® Coffee and Tea Systems
Tel (502) 425-4776 • Fax (502) 425-4664 • 1-800-695-4500 (USA & Canada only)

P.O. Box 35020 • Louisville, KY 40232 • USA

© Grindmaster Corporation, 2003
PRINTED IN USA

www.grindmaster.com • email: info@grindmaster.com

0905 Form # AM-298-05