

# MAXIMIZER

## Pizza Ovens

MODEL B121

### General Features:

- **Quality Construction**  
for long life
- **Stainless steel exterior**
- **Pizza Deck Standard**  
110v: 27" x 19" x 1/2" hearth  
220v: 27" x 19" x 1" hearth
- **Large capacity**  
500 sq. inches of hearth space.  
Two 12" pizzas, one 16" pizza  
or one 18"x26" bun pan
- **Energy efficient**  
Unique design, heavily insulated
- **Great recovery**  
Unique deck and element design  
allows the B121 to recover better  
than other units with twice the  
power
- **Digital electronic controller**  
Standard
- **Cooling fan for longer  
control life**
- **Easily Serviceable**  
Controls accessible in the front  
of the unit
- **Warranty**  
One year parts and labor
- **Power**  
Electric - 110V or 220V
- **Single Phase Standard**
- **Specific features**  
of the B121 are listed  
on the back



**ELECTRIC  
ONLY**



### MORE FOR LESS

- More Cooking Space per Floor Space
- More Cooking Capacity per Sales Dollar
- More Performance per Gas Dollar



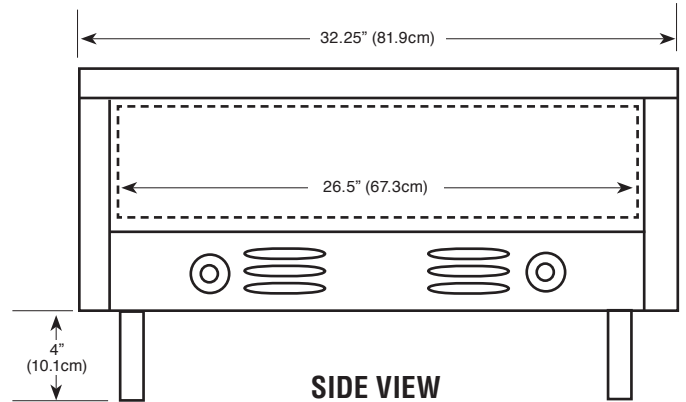
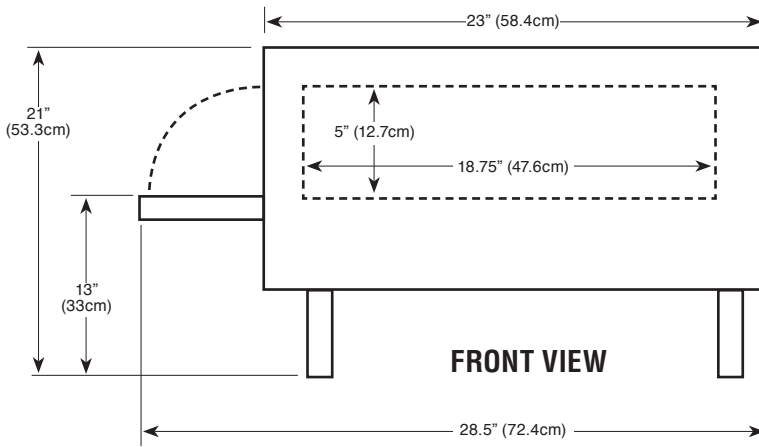

**Counter space . . . . . 32.5" (82.5cm) wide x 22.5" (57.2cm) deep\* x 21" (53.3cm) high**  
**Shelf size . . . . . 26.5" (67.3cm) wide x 18.75" (47.6cm) deep x 5" (12.7cm) high**  
**Shipping weight . . . . . 205 lbs (92.9kg)**  
**Capacity . . . . . Two 12" (30.4cm) pizzas or one 16" (45.7cm) x 26" (66cm) bun pan**  
**Electric . . . . . 2KW - 2,000 watts @ 120V, 20 amps**  
**5KW - 5,000 watts @ 240V, 20 amps, single phase**  
 \* Handle adds 2.5" (6.4cm) to depth



Digital Electronic Controller (Electric Models)



Adjustable Legs

### Durable Construction

The B121 is built starting with an integral **16-gauge stainless steel frame**. The interior is made of Armco type 1, 20-gauge, aluminized steel all sitting on a **18-gauge, aluminized base**. The B121 come standard with **20-gauge, stainless steel front, sides and top**.

### Energy Efficiency

The B121 is equipped with two **1,000 watt elements** and comes standard as a 110V unit. With our unique interior, deck design and heavy insulation, the B121 **will idle with efficiency and recover upon demand**. The B121 is also available as a 220V unit, which has 5,000 watts @240V and will recover better at peak times.

### Versatility and Capacity

The B121 sports a large **26.5"x18.75"x5" compartment** which will hold two 12" pizzas, one 16" pizza, but better yet, will hold an 18"x26" bun pan of just about anything you might want to cook. Hors d'oeuvres, sandwiches, breakfast rolls, you name it... the B121 can cook it! Now that's true versatility.

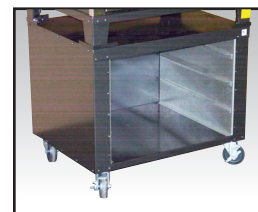

### B121 STAND

- Sideliners hold racks or stones
- Optional casters (shown)
- Optional racks (3)
- 30" (76.2cm) x 22.625" (57.5cm) x 26.25" (66.5cm)

### Design Plus

The B121 has the **controls located in the air-conditioned lower front for ease of operation, space savings and long life**. The door on the B121 has no springs, latches or breakable brackets for **years of trouble-free life**.

