



STAINLESS STEEL EVERYDAY BUFFET HOT FOOD TABLE WITH OPEN BASE



B3-120-B Shown

FEATURES:

4" Swivel Casters, with two brakes
Double sided sneeze guard & side panels
Fiberglass insulation

For Use with Optional Spillage Pans



MATERIAL:

TOP: 20 gauge #304 stainless steel with die stamped pan openings. (12" x 20")
BODY: 20 gauge steel available in matte black vinyl clad
SNEEZE GUARD: 1/4" Thermoplastic Polymer
INSULATION: Fiberglass insulation
HEAT COMPARTMENT: 20 gauge aluminum with exposed dome shape element (S/S wells optional)
LINERS: 8" deep, 22 Gauge galvanized or #302 stainless steel. Requires spillage pans, Add **Model # SP-A** (Aluminum) or **Model # SP-S** (S/S)

ELECTRICAL:

Single phase wiring
120V units yield 500 Watts
208V/240V dual voltage units yield 750 Watts at 208V and 1000 Watts at 240V
6' electrical cord with plug
Infinite control knobs
Indicator lights
Upgrade 240 volt units to 3 Phase wiring - **Model SU-72**

Item #: _____ Qty #: _____
Model #: _____
Project #: _____

GALVANIZED LINERS	STAINLESS STEEL LINERS	Length	Width	Height	# of Wells	Weight (lbs.)	Cubic Feet	Volts	NEMA Plug	Power Consumption
B2-120-B	B2-120-B-S	31.8125"	22.625"	56.15"	2	135	39	120	5-20P	15/500
B3-120-B	B3-120-B-S	47.125"	22.625"	56.15"	3	246	56	120	5-20P	15/500
B4-120-B	B4-120-B-S	62.4375"	22.625"	56.15"	4	301	73	120	L5-30P	20/500
B2-240-B	B2-240-B-S	31.8125"	22.625"	56.15"	2	135	39	208/240	6-20P	15/750 • 20/1000
B3-240-B	B3-240-B-S	47.125"	22.625"	56.15"	3	170	57	208/240	6-20P	15/750 • 20/1000
B4-240-B	B4-240-B-S	62.4375"	22.625"	56.15"	4	310	73	208/240	L6-30P	20/750 • 30/1000
B5-240-B	B5-240-B-S	77.75"	22.625"	56.15"	5	343	90	208/240	L6-30P	20/750 • 30/1000

NOTE: Units are not designed to cook or heat frozen or refrigerated foods. Food placed in tables should already be hot, and the table will maintain the proper temperatures



NEMA PLUG 5-20P



NEMA PLUG 6-20P



NEMA PLUG L5-30P



NEMA PLUG L6-30P

Optional Accessories



Stationary Shelf



Drop-Down Shelf



Stationary Shelf



Drop-Down Shelf

10" Wide Stainless Steel Tray Shelves

STATIONARY DROP-DOWN

Model	Model	Length	Approx Wt.	Cu. ft.
TTS-2	TTS-2D	31.8125"	14 lbs.	3
TTS-3	TTS-3D	47.125"	16 lbs.	4
TTS-4	TTS-4D	62.4375"	18lbs.	5
TTS-5	TTS-5D	77.75"	21 lbs.	6

Visit our website for more Everyday Buffet Accessories!

10" Wide Stainless Steel Tray Rails

STATIONARY DROP-DOWN

Model	Model	Length	Approx Wt.	Cu. ft.
TTR-2	TTR-2D	31.8125"	14 lbs.	3
TTR-3	TTR-3D	47.125"	16 lbs.	4
TTR-4	TTR-4D	62.4375"	18lbs.	5
TTR-5	TTR-5D	77.75"	21 lbs.	6



Customer Service Available To Assist You 1-800-645-3166 8:30 am - 8:00 pm E.S.T.

For Orders & Customer Service:

Email: customer@advancetabco.com or Fax: 631-242-6900

For Smart Fabrication™ Quotes:

Email: smartfab@advancetabco.com or Fax: 631-586-2933

DIMENSIONS and SPECIFICATIONS

TOL ± .125"

ALL DIMENSIONS ARE TYPICAL

2 COMPARTMENT

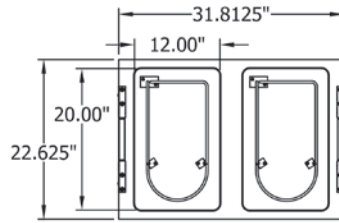

3 COMPARTMENT

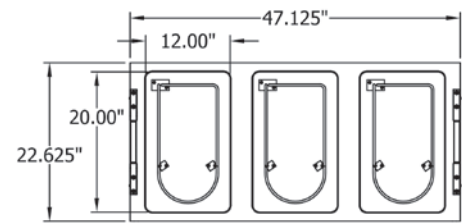

SIDE VIEW

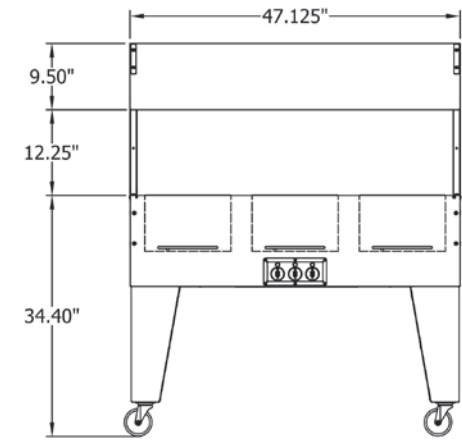
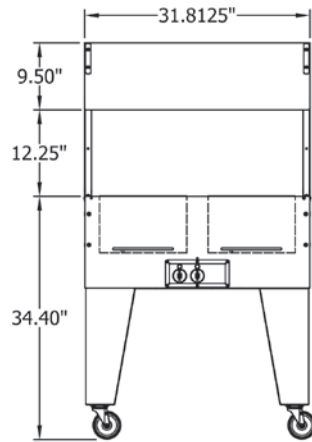
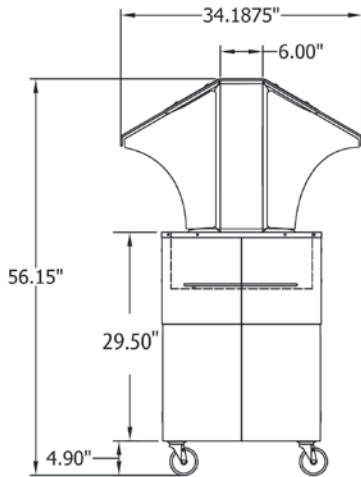

4 COMPARTMENT

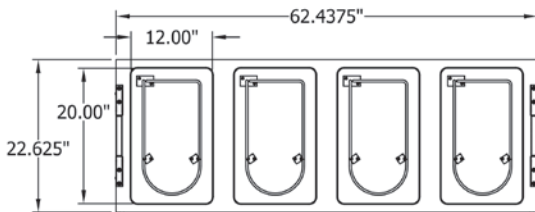

5 COMPARTMENT

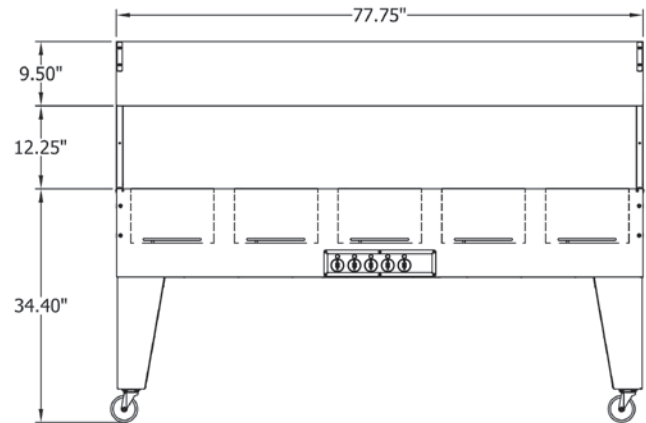
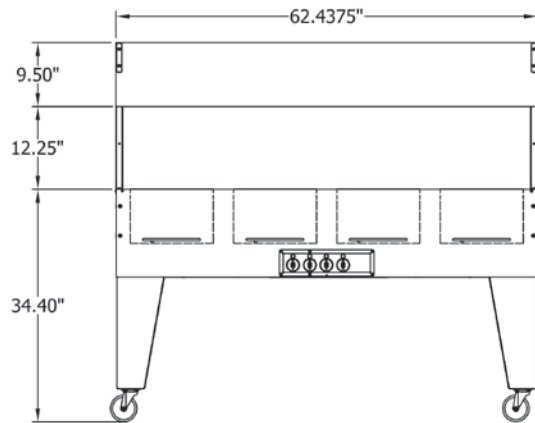
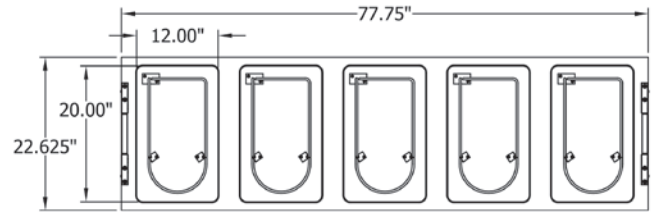

ADVANCE TABCO is constantly engaged in a program of improving our products. Therefore, we reserve the right to change specifications without prior notice.