



BEVERAGE-AIR

Project: _____

AIA#

Item: _____

Location: _____

SIS#

Approved: _____

BB BAR EQUIPMENT - BACK BAR REFRIGERATOR

BB24HC Glass Door
Hydrocarbon Series

MODELS:
BB24HC-1-G-B
BB24HC-1-G-S

BB24HC Back Bar Refrigerators: Glass Door Model

3 Year Parts/Labor Warranty
Additional 2 Year Compressor Warranty



BB24HC-1-G-B

CABINET CONSTRUCTION

- Black or stainless steel exterior
- Interior construction utilizes galvanized steel on walls and ceiling, heavy duty stainless steel floor
- Full electronic control
- Stainless steel top
- Heavy duty stainless steel floor
- Two (2) epoxy coated shelves per section, standard
- Self-closing door
- Stay-open feature & lock standard
- Field reversible doors
- LED lighting
- Packaged products only
- (4") heavy duty casters
- Balanced, forced air refrigeration system provides rapid chilling of product
- Maintains product temperature between 36°F and 38°F

OPTIONS & ACCESSORIES

- For Stainless steel interior (refer to -F models)
- Wine model (40°-60° models)
- Food rated models available
- Underbar model option
- Solid door

REFRIGERATION SYSTEM

- Refrigeration system uses R290 refrigerant to comply with all environmental concerns
- Automatic, non-electric defrost
- Epoxy coated evaporator coil



3779 Champion Blvd., Winston-Salem, NC 27105
1-888-845-9800 Fax: 1-336-245-6453
Beverage-Air.com sales@bevair.com



BEVERAGE-AIR

Bar Equipment-Back Bar Refrigerator Glass Door

Models: BB24HC-1-G-B, BB24HC-1-G-S

MODEL	BB24HC-1-G-B	BB24HC-1-G-S
EXTERNAL DIMENSIONAL DATA		
Width Overall	24"	24"
Depth Overall with Handle	30 1/8"	30 1/8"
Height Overall with 4" Casters	37 3/4"	37 3/4"
Number of Doors	1	1
Depth With Door Open 90°	50 3/4"	50 3/4"
Door Opening (in)	28" x 19 3/4"	28" x 19 3/4"
INTERNAL DIMENSIONAL DATA		
NET Capacity (cubic ft.)	7.66	7.66
Internal Width Overall (in)	20"	20"
Internal Depth Overall (in)	22 1/4"	22 1/4"
Internal Height Overall (in)	29 1/2"	29 1/2"
Number of Shelves	2	2
Number of 1/2 Kegs	1	1
ELECTRICAL DATA		
Full Load Amperes 115/60/1	2	2
REFRIGERATION DATA		
Horsepower	1/6	1/6
Capacity (BTU/Hr)*	993	993
WEIGHT DATA		
Gross Weight (Crated lbs)	192 lbs	202 lbs
Height - Crated	46"	46"
Width - Crated	27"	27"
Depth - Crated	32"	32"

Model Views

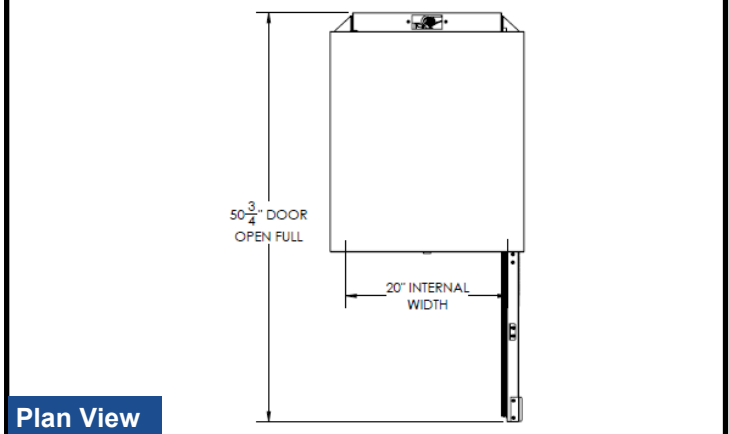

Plan View

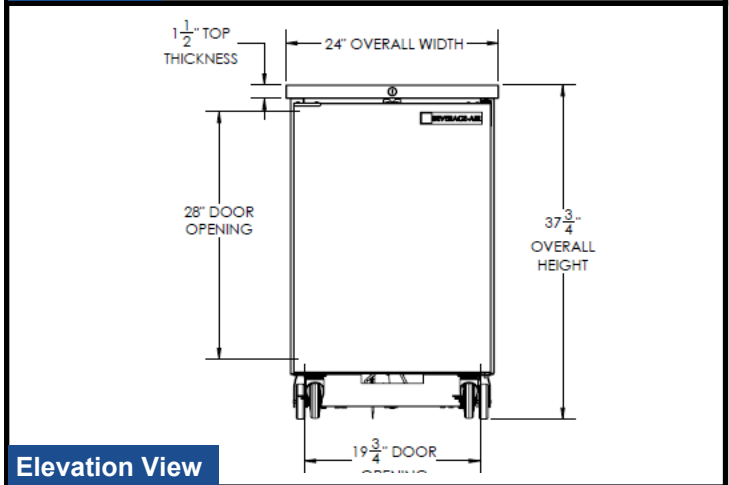

Elevation View

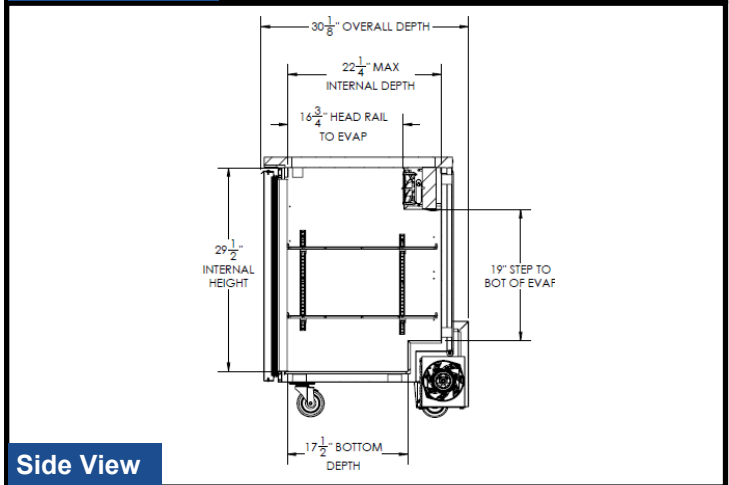

Side View

ELECTRICAL CONNECTION

Units pre-wired at factory and include 8' long cord and plug set.



115/60/1
NEMA-5-15P



an Ali Group Company



The Spirit of Excellence

3779 Champion Blvd., Winston-Salem, NC 27105
1-888-845-9800 Fax: 1-336-245-6453
Beverage-Air.com sales@bevair.com