



RESOURCES

UNDERBAR REFRIGERATION



Use your smart phone to scan the above QR code to visit our website: www.bk-resources.com

Model:

BC-3-95

Bottle Cooler



BC-3-95

• Heavy Duty Construction

Top is made of solid 18 gauge stainless steel for easy cleaning.
Wear resistant black vinyl exterior.
Galvanized interior with SS floor and coved corners.
Anodized aluminum bottle rails.
Drain located in rear of cabinet to keep unit pristine at all times.

• Enhanced Refrigeration System

Factory engineered oversized and balanced refrigeration system.
CFC-free R-134a refrigerators maintain temperature between 33°F to 38°F
Keeps beers ice cold.

• Analog Thermostat

• High Density Polyurethane Insulation

The entire unit has 1.5" CFC-free polyurethane insulation foamed in place for extra strength and energy efficiency.

• Rugged, Removable Bottle Cap Opener & Cap Catcher

• Heavy Duty Adjustable Bin Dividers, Epoxy Coated

PRODUCT DATA SHEET

Specifications subject to change without notice

MODEL	DOORS	CAPACITY		AMPS	HP	VOLTAGE	NEMA PLUG	CORD LENGTH	CABINET DIMENSIONS			SHIPPING	
		12 Oz Can	12 Oz Bottles						L	W*	D	WT.	CUBES
BC-3-95	3	1,150	547	6.2	1/2	115/60/1	5-15P	8'	95"	26 1/2"	33 3/8"	508	69

* Depth does not include 1" bumper and cap catcher
Bottle capacity refers to 12 oz. longneck bottles



ISO 14001

ISO 9001

Conforms to UL and NSF-7 standards

Phone: 888-310-4393

Fax: 888-310-4394

Website: www.bk-resources.com

Email: sales@bk-resources.com

RESOURCES





RESOURCES

UNDERBAR REFRIGERATION

Model:

BC-3-95

Bottle Cooler

Construction

- 18 gauge stainless steel top and stylish black vinyl finish front, sides and back. Interior built of galvanized steel walls with coved corner stainless steel floor.
- Interior LED light.
- The entire cabinet has a 1-1/2" CFC-free, polyurethane insulation foamed-in-place.

Refrigeration System

- Oversized and balanced refrigeration system.
- Self-contained capillary tube system using environmentally friendly and CFC-free refrigerant. R-134a holding temperature at 33°F to 38°F.
- Front breathing/side mount compressor for ease of service and placement in narrow spaces. Condensing unit is behind the front grill, slides out for easy cleaning and maintenance.
- Forced air cooling system for faster cooling and constant temperature in the cabinet.

- Large fan motor and fan blades for better air circulation.
- Self contained system, no plumbing necessary.
- Analog thermostat.

Standard Extras

- Rugged, removable bottle cap opener and cap catcher.
- Heavy duty, epoxy coated adjustable bin dividers.

Electrical

- Each unit is completely pre-wired at factory with cord and plug set included and ready for final connection to a 11/60/1 phase.
- 220V/50hz/1ph available



115/60/1
Nema-5-15P

Warranty

- Continental USA & Canada
- One year labor and parts
 - Five year compressor
 - International: one year parts only

Options & Accessories

- Additional bin dividers
- 3" Casters
- 220v-50Hz-1Phase

Plan View

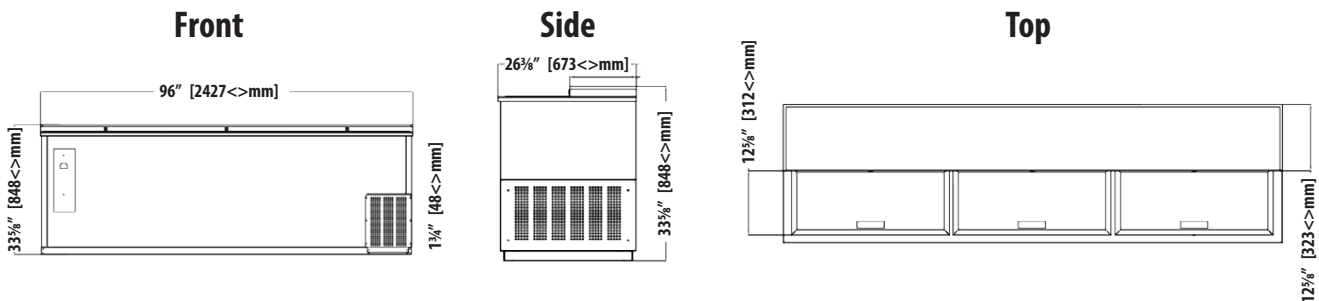

ISO 14001
ISO 9001

Conforms to UL and NSF-7 standards