



# ELECTRIC COUNTER TILTING SKILLET



### SPECIFICATIONS:

Shall be a Southbend model BECT-12 electrically heated counter tilting skillet, c-CSA-us and NSF certified. The skillet shall have a one-piece covered corner, 10 gauge stainless steel pan with satin finish exterior and polished interior. Heating shall be accomplished by electric elements cast embedded into a full 1-1/2" (38mm) thick aluminum casting clamped to the underside of the pan for even heat distribution across the entire surface.

The skillet pan shall be mounted on side pivots to allow tilting for complete removal of contents by means of a tilting handle with a heat proof knob. A tilt position device shall permit the pan to be tilted forward slightly during cooking to aid in grease removal. The mounting base shall include concealed mounting lugs for bolting unit to a counter top or optional stand.

The controls shall be integrally mounted in the stainless steel clad housing and shall include a power switch, thermostat, pilot light and high temperature cut-off.

The skillet shall operate in a temperature range of 160°F to 445°F (71°C to 230°C).

MODEL	CAPACITY	
BECT-12	12 Gallon	45 Liter

### OPERATION SHALL BE BY:

Electric heating elements equipped for operation on:

- 208 VAC, 1 or 3 Phase, 50/60 Hz
- 220 VAC, 1 or 3 Phase, 50/60 Hz
- 240 VAC, 1 or 3 Phase, 50/60 Hz
- 415/240 VAC, 3 Phase, 4 wire, 50/60 Hz
- 380/220 VAC, 3 Phase, 4 wire, 50/60 Hz

### OPTIONAL ITEMS AT EXTRA COST:

- 380, 415, 480 or 600 VAC, 3 Phase, 50/60 Hz
- Steam pan insert (SPI-12)
- Etched gallon markings (GMS-12)
- Etched liter markings (LMS-45)
- One piece lift off stainless steel cover (SC-12)
- Pour strainer (PS-12)
- 30" wide, open leg base, stainless steel kettle stand with sliding shelf (KEDC-30)
- 30" wide, open leg base, stainless steel kettle stand with sliding drain drawer (KEDC-30SD)
- Single pantry faucet with 12" swing spout (SF-12)
- Double pantry faucet with 12" swing spout (DF-12)
- Single pantry faucet & bracket with 60" pot filler (SF-60)
- Double pantry faucet & bracket with 60" pot filler (DF-60)
- Single faucet spray hose with bracket (SF-SH)
- Double faucet spray hose with bracket (DF-SH)
- Marine Lock (ML-1)
- Correctional Package

Job  
Item#



Models:  BECT-12

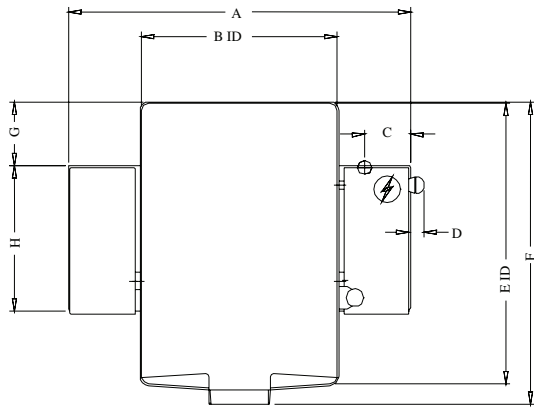

DIMENSIONS ARE IN INCHES [MM]

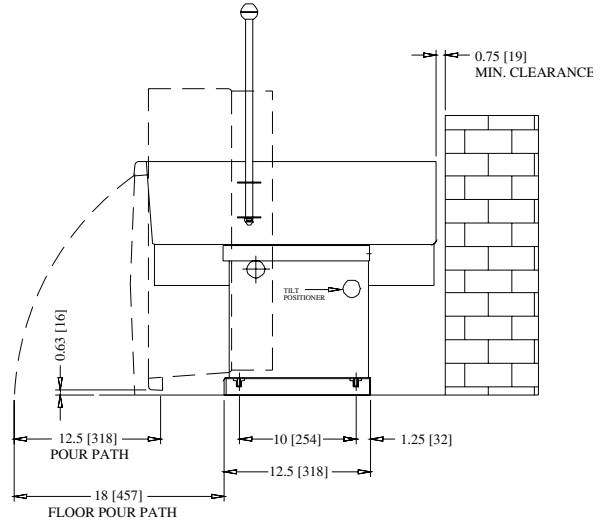
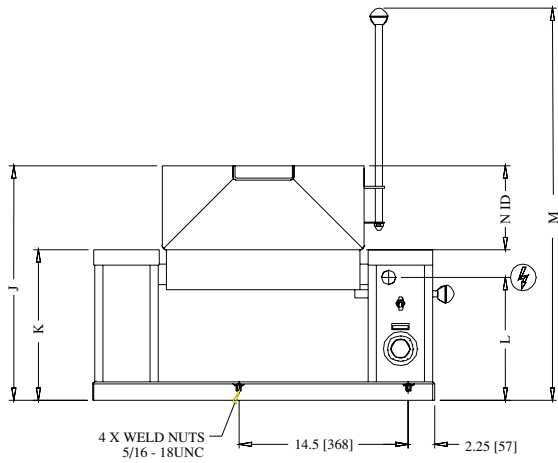

**DIMENSIONS**

MODEL	SHIPPING WEIGHT	CAPACITY	UNITS	A	B	C	D	E	F	G	H	J	K	L	M	N	MIN. CLEARANCE
BECT-12	191 lbs. (87 kg)	12 Gallons (45 liters)	inches (mm)	29" (737)	16.75" (425)	4" (102)	2" (51)	24" (610)	25.75" (654)	5.5" (140)	12.5" (318)	20" (508)	13" (330)	10.5" (267)	33.25" (845)	7" (178)	Sides 6" (152) Back 6" (152)

**ELECTRICAL CHARACTERISTICS**

MODEL	P <sub>H</sub>	208V		220V		240V		380V		415V		480V		kW	AMP
		kW	AMP	kW	AMP	kW	AMP	kW	AMP	kW	AMP	kW	AMP		
BECT-12	1	9.0	43.3	9.0	40.9	9.0	37.5	--	--	--	--	--	--	--	--
	3	9.0	25.0	9.0	23.6	9.0	21.7	9.0	13.7	9.0	12.5	9.0	10.8	9.0	8.7

**SERVICE CONNECTIONS**

⚡ – ELECTRICAL CONNECTION: Specify 208, 220 or 240 volt, single or three phase, 60 Hz single phase with grounding wire.

**INTENDED FOR COMMERCIAL USE ONLY.  
NOT FOR HOUSEHOLD USE.**



1100 Old Honeycutt Road, Fuquay-Varina, NC 27526  
(919) 762-1000 www.southbendnc.com