



ELECTRIC TILTING SKILLET

Job

Item#



MODEL	CAPACITY	
BECT-30	30 Gallon	114 Liter
BECT-40	40 Gallon	152 Liter

OPERATION SHALL BE BY:

Electric heating elements equipped for operation on:

- 208 VAC, 3 phase, 50/60 Hz
- 220 VAC, 3 phase, 50/60 Hz
- 240 VAC, 3 phase, 50/60 Hz
- 380/220 VAC, 3 phase, 50/60 Hz
- 415/240 VAC, 3 phase, 50/60 Hz

OPTIONAL ITEMS AT EXTRA COST:

- 380 VAC, 3 phase, 50/60 Hz
- 415 VAC, 3 phase, 50/60 Hz
- 480 VAC, 3 phase, 50/60 Hz
- 600 VAC, 3 phase, 60 Hz
- Etched gallon markings (GMS-30, GMS-40)
- Etched liter markings (LMS-30, LMS-40)
- 2" (51 mm) draw-off valve with strainer (TVT-2BP)
- 3" (76 mm) draw-off valve with strainer (TVT-3BP)
- 60 minute mechanical timer mounted on left console
- Casters
- Correctional package

ACCESSORIES:

- Pan carrier (PC-1)
- Steam pan insert (SPI-30, SPI-40)
- 12" Single pantry faucet with swing spout (SF-12)
- 12" Double pantry faucet with swing spout (DF-12)
- Single pantry faucet and bracket with 60" pot filler (SF-60)
- Double pantry faucet and bracket with 60" pot filler (DF-60)

SPECIFICATIONS:

Shall be a Model _____, electrically heated tilting skillet, c-CSA-us and NSF Certified. The skillet shall be of one piece covered corner, 10 gauge T-304 stainless steel with a #4 exterior finish and a polished interior. Heating shall be accomplished by electric elements embedded in a full 1-3/8" (35 mm) thick aluminum casting bolted to the underside of the pan for even heat distribution across the entire surface. Pan shall pivot on side trunnions connected to the gear and control consoles. The consoles shall be drip proof, stainless steel clad and shall be supported by an all welded 1-5/8" (41 mm) stainless steel pipe frame with front legs fitted with adjustable bullet feet and rear legs fitted with flange adjustable feet for securing to the floor. The worm and gear tilt mechanism shall allow the pan to tilt forward manually for complete emptying of contents. The controls shall be integrally mounted in the left console and shall include a thermostat, power switch and pilot light. As a safety feature the pan shall be equipped with a high limit thermostat on each element assembly to shut down operation should the thermostat fail.

Convenience features shall include a spring assist hinged stainless steel cover with handle and no drip condensate guide, vent port with swing cover and a removable pour strainer on the pour lip.

The skilled shall operate in a temperature range of 160°F to 445°F (71°C to 229°C) with a high temperature safety cut-off at 500°F (260°C).



Models: BECT-30 BECT-40

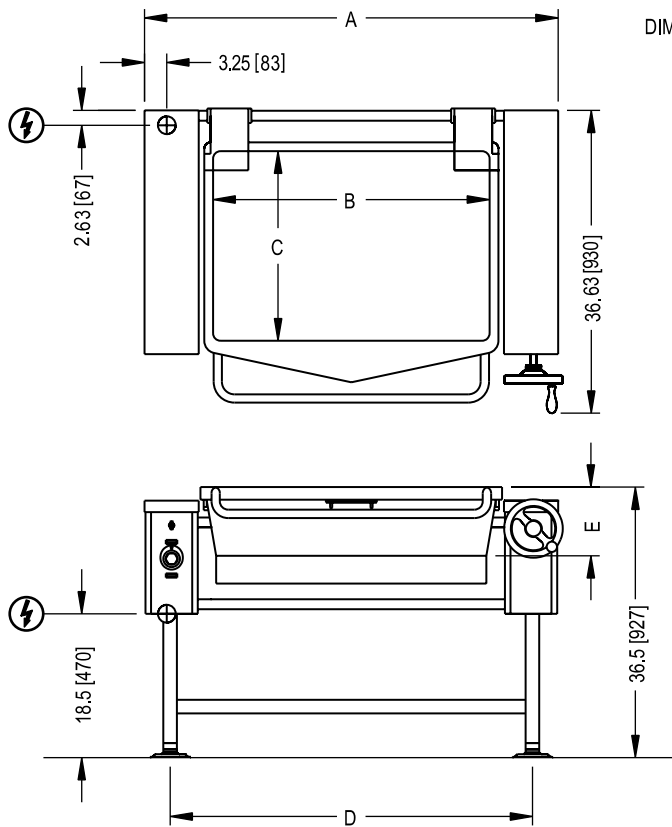

DIMENSIONS ARE IN INCHES [MM]



REAR FLANGED FOOT DETAIL
 4 EQUALLY SPACED
 Ø7/16" [11mm] HOLES
 ON 3 [76] B.C.

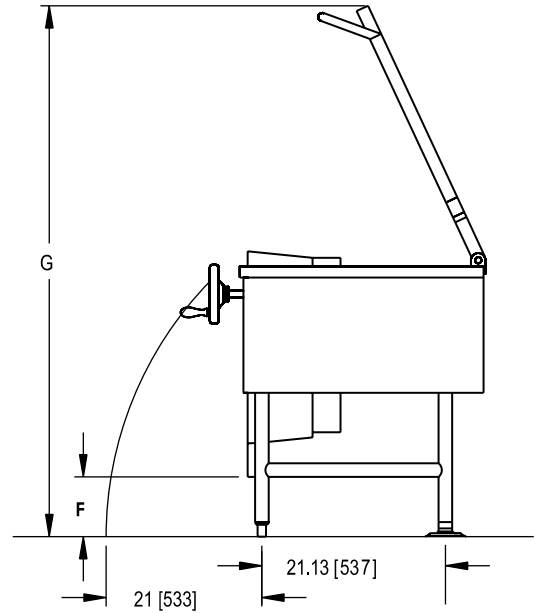

DIMENSIONS

MODEL	SHIPPING WEIGHT	CAPACITY	UNITS	A	B	C	D	E	F	G	MINIMUM CLEARANCE	
BECT-30	530 lbs. (240 kg)	30 Gallons (114 liters)	inches (mm)	49.75" (1264)	32.88" (835)	23.50" (597)	43.13" (1095)	9.25" (235)	11" (279)	67.63" (1718)	SIDES	6" (152)
BECT-40	642 lbs. (291 kg)	40 Gallons (152 liters)	inches (mm)	59" (1499)	42.88" (1089)	23" (584)	52.50" (1334)	9.25" (235)	11" (279)	67.63" (1715)	BACK	6" (152)

ELECTRICAL CHARACTERISTICS

MODEL	kW	
	STANDARD	OPTIONAL
BECT-30	18	12
BECT-40	27	18

kW	PHASE	AMPS PER LINE					
		208V	220V	240V	380V	415V	480V
12	1	57.7	54.5	50.0	N/A	N/A	N/A
	3	33.3	31.5	28.9	18.2	16.7	14.4
18	1	86.5	81.8	75.0	N/A	N/A	N/A
	3	50.0	47.2	43.3	27.3	25.0	21.7
27	3	75.0	70.9	65.0	41	37.6	32.5

SERVICE CONNECTIONS

⚡ – ELECTRICAL CONNECTION: As specified on data plate.

**INTENDED FOR COMMERCIAL USE ONLY.
 NOT FOR HOUSEHOLD USE.**



1100 Old Honeycutt Road, Fuquay-Varina, NC 27526
 (919) 762-1000 www.southbendnc.com