



BEVERAGE-AIR

Project: _____

AIA#

Item: _____

Location: _____

SIS#

Approved: _____

BM BAR EQUIPMENT-BARMOBILE

MODELS:
BM23HC-S-31

BM23HC Outdoor Portable Draft Beer Dispenser

Hydrocarbon Series



BM23HC-31

3 Year Parts/Labor Warranty
Additional 2 Year Compressor Warranty

CABINET CONSTRUCTION

- Exterior is stainless steel
- Interior construction utilizes galvanized steel on walls and ceiling, doorsill is stainless steel, reinforced floor made from heavy duty stainless steel
- Top is made from heavy-duty stainless steel including drip tray
- Full electronic control
- Tower has continuous source of cold air
- Three-inch (3") insulated tower with single faucet
- Beer waste bottle to capture beer from drain
- Self-closing doors with locks, standard
- Magnetic door gaskets for positive door sealing
- Field reversible door
- Four-inch (4") heavy duty casters
- Certified for outdoor use
- Balanced, forced-air refrigeration system keeps beer in kegs ice cold for dispensing
- Maintains product temperatures between 36°F and 38°F

OPTIONS & ACCESSORIES

- Stainless steel or black exterior club models available
- Wine models available
- Wine tap
- 1- 4 faucet
- 2, 3, or 4-way manifold
- Leg accessory kit
- Remote option

REFRIGERATION SYSTEM

- Refrigeration system uses R290 refrigerant to comply with all environmental concerns
- Automatic, non-electric defrost
- Epoxy coated evaporator coil

BM23HC Draft Beer Equipment Barmobile: BM Series



3779 Champion Blvd., Winston-Salem, NC 27105
1-888-845-9800 Fax: 1-336-245-6453
Beverage-Air.com sales@bevair.com



BEVERAGE-AIR

Bar Equipment—Portable Draft Beer Dispenser Outdoor Dispenser Models: BM23HC-S-31

MODEL	BM23HC-S-31
EXTERNAL DIMENSIONAL DATA	
Width Overall	24"
Depth Overall	30 1/8"
Height Overall with 4" Casters & Tap	53"
Number of Doors	1
Depth With Door Open 90°	50 3/4"
Clear Door Opening (in)	19 3/4" x 28"
INTERNAL DIMENSIONAL DATA	
NET Capacity (cubic ft.)	7.66
Internal Width Overall (in)	20"
Internal Depth Overall (in)	22 1/4"
Internal Height Overall (in)	23 1/2"
Number of Kegs	1
ELECTRICAL DATA	
Full Load Amperes 115/60/1	2
REFRIGERATION DATA	
Horsepower	1/6
Capacity (BTU/Hr)*	993
WEIGHT DATA	
Gross Weight (Crated lbs)	180 lbs
Height - Crated	43"
Width - Crated	27"
Depth - Crated	32 1/2"

Model Views

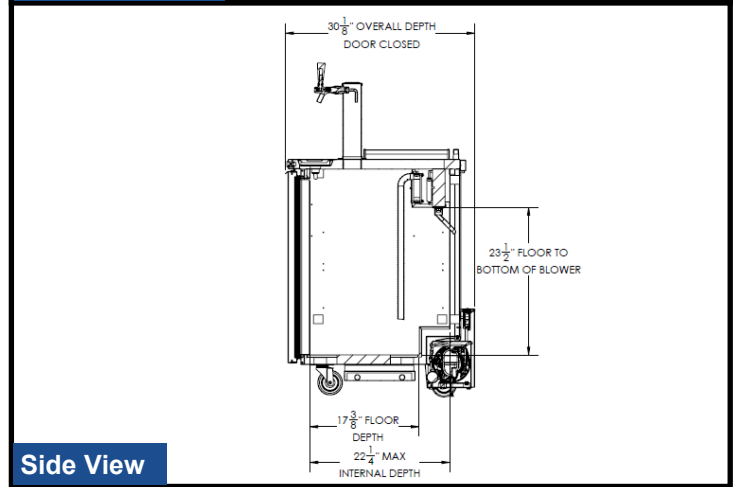
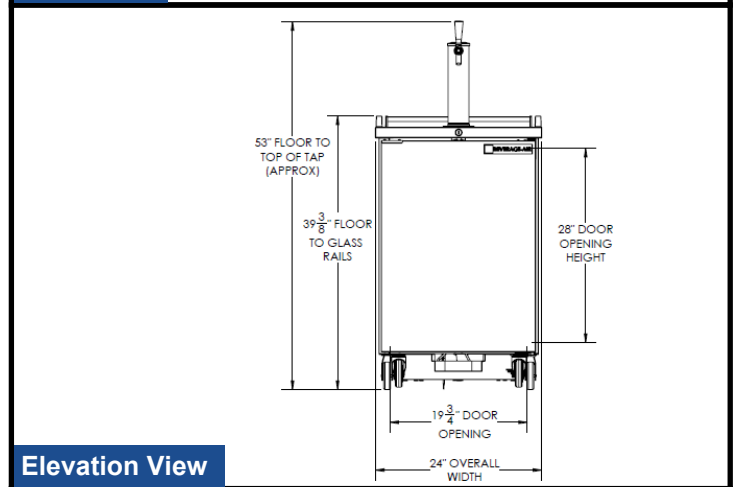
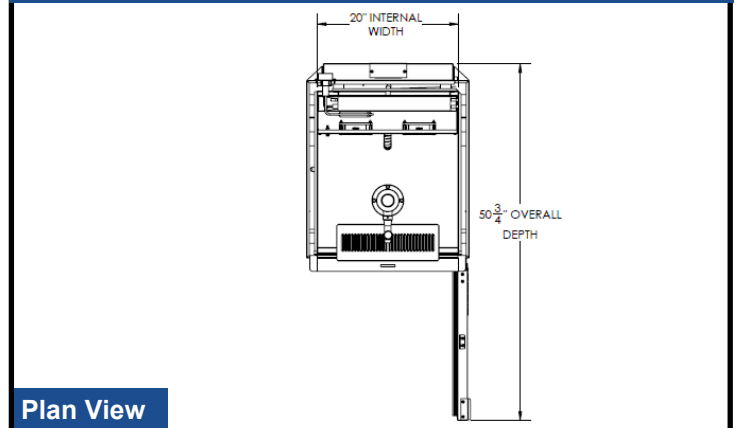

ELECTRICAL CONNECTION



115/60/1
NEMA-5-15P

Units pre-wired at factory and include 8' long cord and plug set.



an Ali Group Company



The Spirit of Excellence

3779 Champion Blvd., Winston-Salem, NC 27105
1-888-845-9800 Fax: 1-336-245-6453
Beverage-Air.com sales@bevair.com