



BEVERAGE-AIR

Project: _____	AIA#
Item: _____	
Location: _____	SIS#
Approved: _____	

GF BAR EQUIPMENT

GF48L Glass and Plate Froster

MODEL:
GF48L-B
GF48L-S



GF48L-B



GF48L-S

3 Year Parts/Labor Warranty
Additional 2 Year Compressor Warranty

CABINET CONSTRUCTION

- Exterior is available in wear resistant vinyl on steel in black Finish or stainless steel finish
- Standard interior construction utilizes galvanized steel
- Top includes easy glide, stainless steel lids and stainless steel counter top with edge
- Full electronic control
- Four (4) shelves and (2) two bottom racks standard
- Two (2) shelf ledges standard with three (3) mounting points
- Chills glasses and plates at -10°F
- Flexibility in design provides for plate storage and chilling
- Automatic defrost of coil is standard
- Built-in condensate evaporator system
- No floor drain or additional plumbing is needed

OPTIONS & ACCESSORIES

- Stainless steel interior
- Locks
- 3" - 6" Casters
- 6" Adjustable legs with plate
- Horizontal mount thermometer
- Dial thermometer
- Remote option

REFRIGERATION SYSTEM

- Refrigeration system uses R404A refrigerant to comply with all environmental concerns
- Automatic, electric defrost
- Epoxy coated evaporator coil

GF48L Bar Equipment: Glass and Plate Froster Series



3779 Champion Blvd., Winston-Salem, NC 27105
 1-888-845-9800 Fax: 1-336-245-6453
 Beverage-Air.com sales@bevair.com



BEVERAGE-AIR

Bar Equipment - Glass Frosters

Models: GF48L-B, GF48L-S

MODEL	GF48L-B	GF48L-S
EXTERNAL DIMENSIONAL DATA		
Width Overall	48"	48"
Depth Overall	26 1/8"	26 1/8"
Height Overall	33 5/8"	33 5/8"
Number of Lids	2	2
INTERNAL DIMENSIONAL DATA		
NET Capacity (cubic ft.)	9.6	9.6
Internal Width Overall (in)	44"	44"
Internal Depth Overall (in)	22"	22"
Internal Depth Useable (in)	17 1/2"	17 1/2"
Internal Height Overall (in)	18 1/4"	18 1/4"
Number of Dividers	4	4
Number of 12 oz. Mugs	164	164
Number of 8" Plates	250	250
ELECTRICAL DATA		
Full Load Amperes 115/60/1	7.5	7.5
REFRIGERATION DATA		
Horsepower	1/2	1/2
Capacity (BTU/Hr)*	1132	1131
WEIGHT DATA		
Gross Weight (Crated lbs)	292 lbs	292 lbs
Height - Crated	39"	39"
Width - Crated	51 1/2"	51 1/2"
Depth - Crated	29"	29"

Model Views

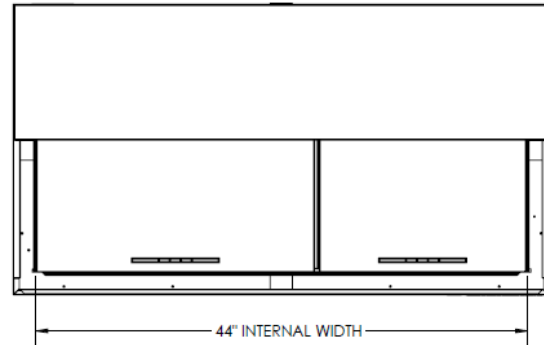

Plan View

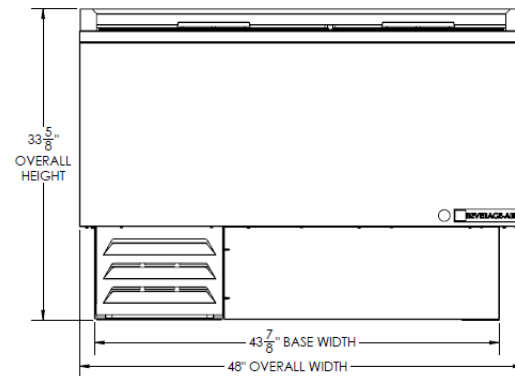

Elevation View

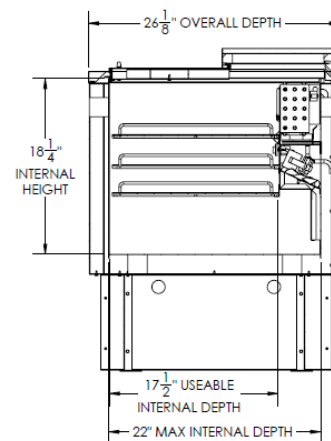

Side View

ELECTRICAL CONNECTION



115/60/1
NEMA-5-15P

Units pre-wired at factory and include 8' long cord and plug set.



an Ali Group Company



The Spirit of Excellence

3779 Champion Blvd., Winston-Salem, NC 27105
1-888-845-9800 Fax: 1-336-245-6453
Beverage-Air.com sales@bevair.com