



BEVERAGE-AIR

Project: _____

AIA#

Item: _____

Location: _____

SIS#

Approved: _____

HFS HORIZON TOP MOUNT REACH-IN

MODELS:

HFS2 Solid Half Doors Top Mount Reach-In Freezer

HFS2-1HS

HFS2 Top Mount Reach-In: Horizon Series

**3 Year Parts/Labor Warranty
Additional 2 Year Compressor Warranty**



HFS2-1HS

CABINET CONSTRUCTION

- Exterior is stainless steel front and gray painted sides
- Interior is stainless steel
- Full electronic control with One-touch defrost
- Expansion valve technology
- One piece grille
- LED interior light
- Self-closing door with 120° stay-open feature, on cam-lift hinges
- Field reversible doors are easily removed for service and cleaning
- Magnetic gasket attached to each door for positive seal
- Door locks
- Anti-microbial door handles
- Three (3) heavy duty epoxy coated wire shelves per section
- 6" Heavy-duty casters, two (2) with brakes
- Maintains product temperatures of 0° F and below

OPTIONS & ACCESSORIES

- Glass and half glass doors
- Solid door with locks
- Epoxy shelves, Clips
- Shelf slide
- Stainless steel breaker
- 6" Legs
- 3" Casters
- Remote option

REFRIGERATION SYSTEM

- Refrigeration system uses R404a refrigerant to comply with all environmental concerns
- Automatic evaporation system for energy efficiency
- Epoxy coated evaporator coil



3779 Champion Blvd., Winston-Salem, NC 27105
1-888-845-9800 Fax: 1-336-245-6453
Beverage-Air.com sales@bevair.com



BEVERAGE-AIR

MODEL	HFS2-1HS
EXTERNAL DIMENSIONAL DATA	
Width Overall	52"
Depth Overall with Handle	33 5/8"
Height Overall with 6" Casters	84 1/2"
Number of Doors	4
Depth with Door Open 90°	55 1/8"
Door Opening (in)	21 5/8" x 29 5/8" (4)
Shelf Area (sq. in)	552 1/2"
INTERNAL DIMENSIONAL DATA	
NET Capacity (cubic ft.)	49
Internal Width Overall (in)	48"
Internal Depth Overall (in)	26"
Internal Height Overall (in)	62"
Number of Shelves	6
ELECTRICAL DATA	
Full Load Amperes 115/60/1	12
REFRIGERATION DATA	
Horsepower	3/4
WEIGHT DATA	
Gross Weight (kgs)	550 lbs
Height - Crated	87 1/2"
Width - Crated	55"
Depth - Crated	35"

Top Mount Reach-In Freezer

Model: HFS2-1HS

Model Views

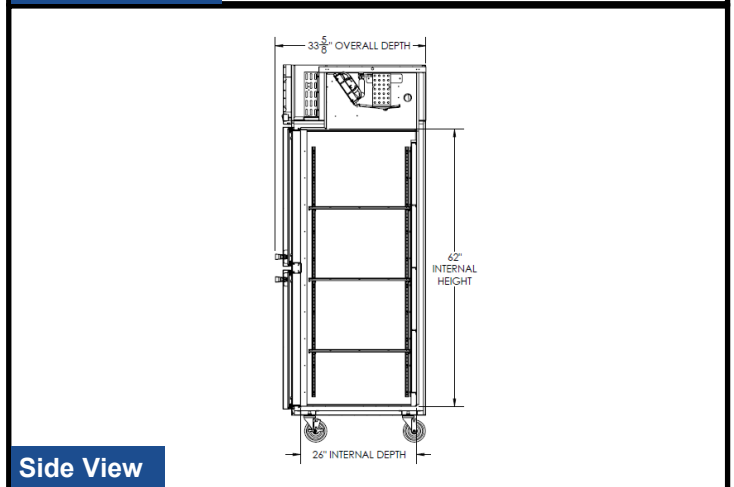
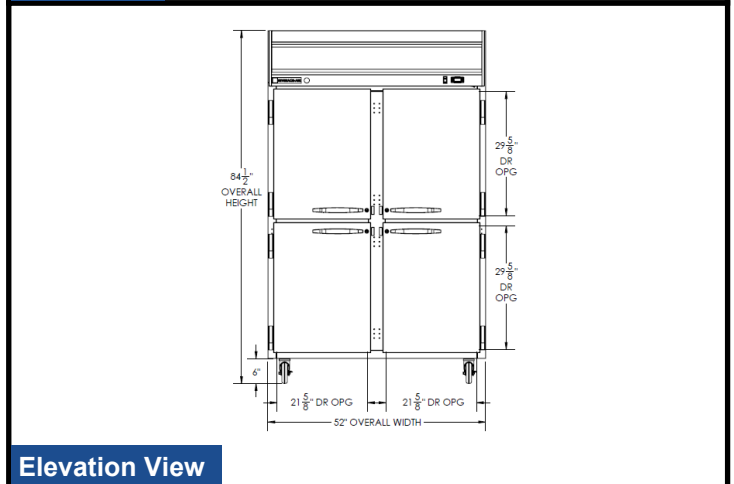
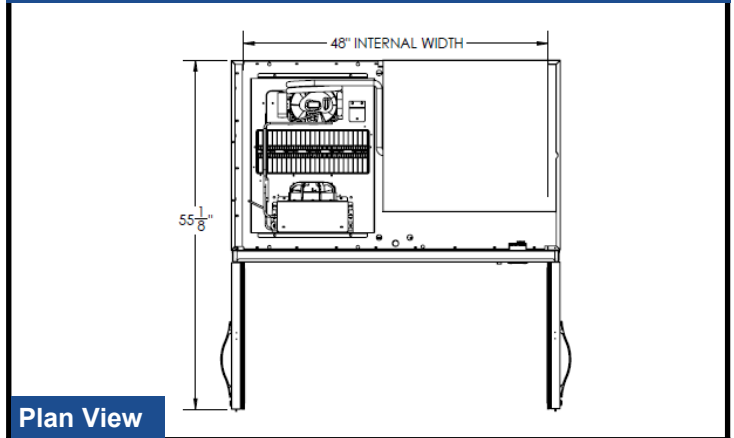

ELECTRICAL CONNECTION



115/60/1
NEMA-5-15P

Units pre-wired at factory and include 8' long cord and plug set.



an Ali Group Company



3779 Champion Blvd., Winston-Salem, NC 27105
1-888-845-9800 Fax: 1-336-245-6453
Beverage-Air.com sales@bevair.com