



BEVERAGE-AIR

Project: _____

AIA#

Item: _____

Location: _____

SIS#

Approved: _____

VM OPEN AIR-MERCHANDISER

VM18 Open Air-Merchandiser

MODEL:

VM18-1-B-LED

VM18-1-G-LED

VM18-1-W-LED



VM18-1-B-LED



VM18-1-W-LED

3 Year Parts/Labor Warranty
Additional 2 Year Compressor Warranty

CABINET CONSTRUCTION

- Exterior is power coated galvanized metal available in black, grey or white
- Interior is painted steel for easy cleaning
- Electronic temperature control
- LowE double pane glass tempered thermal sides
- Foamed in place CFC free polyurethane insulation enhances the structural strength of the cabinet and helps increase energy efficiency
- Shelves included can be installed in 2 position for display flexibility
- Tag molding
- 6" adjustable legs
- Night curtain comes standard and helps save energy and maintain cabinet temperature.
- Operating temperature 36°F - 40°F
- Intended for use in rooms having ambient condition or 75°F/55% humidity
- LED lighting standard

OPTIONS & ACCESSORIES

- 5" Casters
- Bar/Bag hook
- Front Product display
- Side product display
- Lockable security cage

REFRIGERATION SYSTEM

- Refrigerant is R134A
- Maintenance free condenser slides out for easy service
- Automatic defrost

VM VuelMax Series: Open Air-Merchandiser



3779 Champion Blvd., Winston-Salem, NC 27105
1-888-845-9800 Fax: 1-336-245-6453
Beverage-Air.com sales@bevair.com



BEVERAGE-AIR

Open Air-Merchandiser

Models: VM18-1-B-LED, VM18-1-G-LED, VM18-1-W-LED

MODEL	VM18
EXTERNAL DIMENSIONAL DATA	
Width Overall	51 1/2"
Depth Overall	31 2/3"
Height Overall	78 4/5"
INTERNAL DIMENSIONAL DATA	
NET Capacity (cubic ft.)	23.87
Number of Shelves	5
ELECTRICAL DATA	
Full Load Amperes 120/60/1	16
REFRIGERATION DATA	
Horsepower	2x 1/3
Energy Consumption	18.5 kw-hr/day
WEIGHT DATA	
Gross Weight (Crated lbs)	652 lbs
Height - Crated	82 5/7"
Width - Crated	56 2/7"
Depth - Crated	36 2/7"

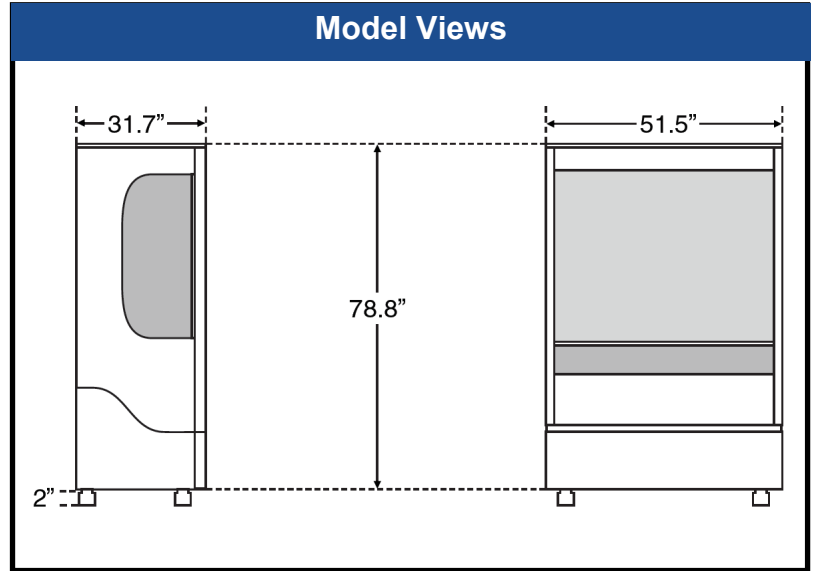

Front Display

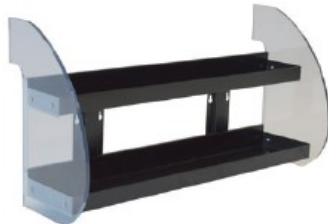

Side Display



Security Cage



ELECTRICAL CONNECTION



115/60/1
NEMA-5-20P

Units pre-wired at factory and include 8' long cord and plug set.



an Ali Group Company



The Spirit of Excellence

3779 Champion Blvd., Winston-Salem, NC 27105
1-888-845-9800 Fax: 1-336-245-6453
Beverage-Air.com sales@bevair.com