



# BEVERAGE-AIR

Project: \_\_\_\_\_

AIA#

Item: \_\_\_\_\_

Location: \_\_\_\_\_

SIS#

Approved: \_\_\_\_\_

## WTRCS WORKTOP CHEF BASE REFRIGERATOR

MODEL:

WTRCS84D-1-96

### WTRCS84D 96" Worktop Refrigerator with Four Drawers



WTRCS84D-1-96

**3 Year Parts/Labor Warranty  
Additional 2 Year Compressor Warranty**

### CABINET CONSTRUCTION

- Stainless steel front, sides, drawers and grille (galvanized back & bottom)
- Interior liner is made of corrosion resistant aluminum
- Full electronic control
- 96" Worktop
- Drawers provide ample food product storage
- Full marine drip-guard to prevent spills from dripping over the edge
- Dynamic load rating of 275 lbs per drawer
- 12 gauge drawer slides with 3 Delrin encased stainless steel roller bearings per each drawer slides - *LIFETIME WARRANTY ON ALL DRAWERS AND SLIDES*
- Heavy duty, fire-proof, reinforced insulated 16 gauge top
- Accommodates 6" deep pans in top & bottom drawers
- Self-closing feature engages in the last 1-2" of travel
- 6" Casters, 3 with brakes standard
- Operates at 36°-38°F for optimum food preservation

### OPTIONS & ACCESSORIES

- 6" Legs
- 3" Casters
- Gasket guards
- Worktop sizes options
- Flat top option
- Remote option

### REFRIGERATION SYSTEM

- Refrigeration system uses R134a refrigerant to comply with all environmental concerns
- Automatic, non-electric defrost
- Epoxy coated evaporator coil

WTRCS84D-1 Refrigerator with 4 Drawers: Worktop Series



3779 Champion Blvd., Winston-Salem, NC 27105  
1-888-845-9800 Fax: 1-336-245-6453  
Beverage-Air.com sales@bevair.com



# BEVERAGE-AIR

## Worktop Refrigerator– With 4 Drawers

Models: WTRCS84D-1-96

MODEL	WTRCS84D-1-96
<b>EXTERNAL DIMENSIONAL DATA</b>	
Width Overall (Cabinet)	84"
Width Overall (Worktop)	96"
Depth Overall with Handle & Bumper	34 3/4"
Height Overall with 6" Casters	26 5/8"
Number of Drawers	4
Depth with Drawer Extended	57 3/4"
Drawer Opening (in)	Left 40 1/4" x 6 1/2" Right 27 3/8" x 6 1/2"
<b>INTERNAL DIMENSIONAL DATA</b>	
NET Capacity (cubic ft.)	17.37
Internal Width Overall (in)	70 1/2"
Internal Depth Overall (in)	26"
Internal Height Overall (in)	16 3/8"
<b>ELECTRICAL DATA</b>	
Full Load Amperes 115/60/1	4.5
<b>REFRIGERATION DATA</b>	
Horsepower	1/3
Capacity (BTU/Hr)*	1690
<b>WEIGHT DATA</b>	
Gross Weight (Crated lbs)	680 lbs
Height - Crated	26"
Width - Crated	101"
Depth - Crated	38"

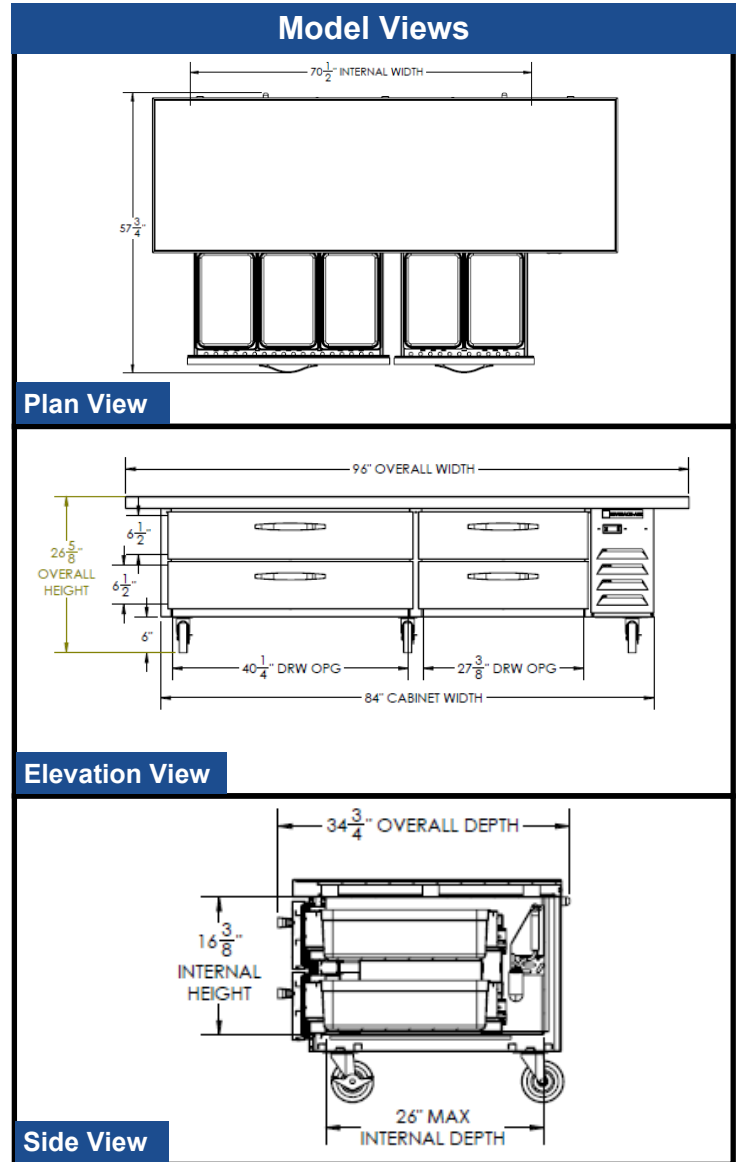

### Large Drawers

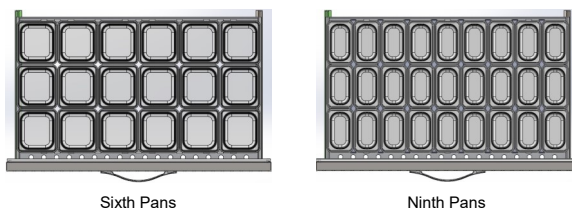
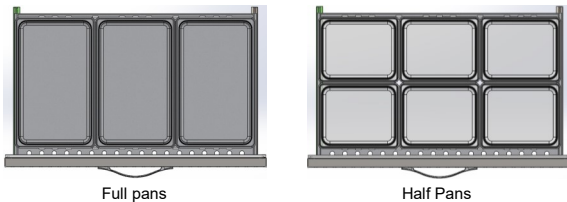

### Small Drawers

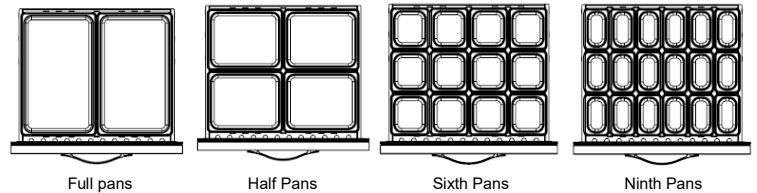

### ELECTRICAL CONNECTION



115/60/1  
NEMA-5-15P

Units pre-wired at factory and include 8' long cord and plug set.



an Ali Group Company



The Spirit of Excellence

3779 Champion Blvd., Winston-Salem, NC 27105  
1-888-845-9800 Fax: 1-336-245-6453  
Beverage-Air.com sales@bevair.com