



BLCM-62G

BLCM-62G

Single Gas

Boilerless Combination-Oven/Steamer



Shown on optional stand with casters

Project _____

Item No. _____

Quantity _____

- Standard pan cassette with 3.35" (85mm) spacing holds five full size sheet pans or ten 12" x 20" x 2-1/2" deep North American hotel pans
- Optional pan cassette with 2.56" (65mm) spacing holds six full size sheet pans or twelve 12" x 20" x 2" deep Gastronorm pans

Refer to operator manual specification chart for listed model names.

CONSTRUCTION

- 304 stainless steel exterior and interior
- Dual pane tempered viewing window with hinged inner glass for easy cleaning
- 2" (50mm) fixed drain in the bottom center of cavity
- Door mounted drip tray reduces the risk of wet, slippery floors
- Automatic door stops in positions 110° and 180° for ease of loading and unloading and improved safety.
- Left hinge door is field convertible to the right side (with the purchase of conversion kit)
- Two step safety door latch. The first step stops the fan.

OPERATION

- Multiple cooking modes include hot air, combi 1 (30-40% steam), combi 2 (60-80% steam), retherming, steaming, low-temperature steaming, forced steam, and preheating
- Automated CombiWash, closed circuit cleaning system features very low water and detergent consumption and no contact with chemicals. No proprietary chemicals required, see owner's manual for detergent guidelines.
- User friendly control with dial and digital display
- Injection steam system - water is injected onto the heat exchanger, the resulting steam is distributed in the oven chamber by the fan wheel.
- Control stores up to 50 recipe programs with 10 cooking stages each
- Reversible 9 speed fan for optimum baking and roasting results
- Programmable time delay start
- 85°-480°F (30°-250°C) temperature range, 575°F (300°C) preheating
- Low water indicator

STANDARD FEATURES

- Cassette support platform
- External core temperature probe with multiple measuring points. User-friendly location reduces strain on the probe
- 31-1/2" tall stainless steel stand with runners & adjustable feet
- Bright halogen lights for superior visibility
- Built in hand shower
- **Removeable cleaning chemical bottle shelf**
- Start-up inspection service by factory authorized service agent
- One year parts and labor oven warranty*

* For all international markets, contact your local distributor.



Intertek

OPTIONS AND ACCESSORIES

(AT ADDITIONAL CHARGE)

Legs and Stands

- 31-1/2" tall stainless steel stand with runners & casters
- Adjustable feet for table top installation

Banquetting Accessories

- Pan cassette with 2.56" (65mm) spacing
- Pan cassette with 3.35" (85mm) spacing
- Plate cassette with 2.56" (65mm) spacing holds 39 plates
- Plate cassette with 3.35" (85mm) spacing holds 33 plates
- Transport trolley, to move the cassette
- Insulated thermal blanket with vent
- Wire oven rack
- Right hinge door
- Extra year warranty

OPTIONS AND ACCESSORIES

(AT NO CHARGE)

- Optional pan cassette with 2.56" (65mm) spacing

BLODGETT OVEN COMPANY

www.blodgett.com • 44 Lakeside Avenue, Burlington, VT 05401 • Phone: (802) 658-6600 • Fax: (802) 864-0183



BLCM-62G



APPROVAL/STAMP

DIMENSIONS ARE IN INCHES (MM)

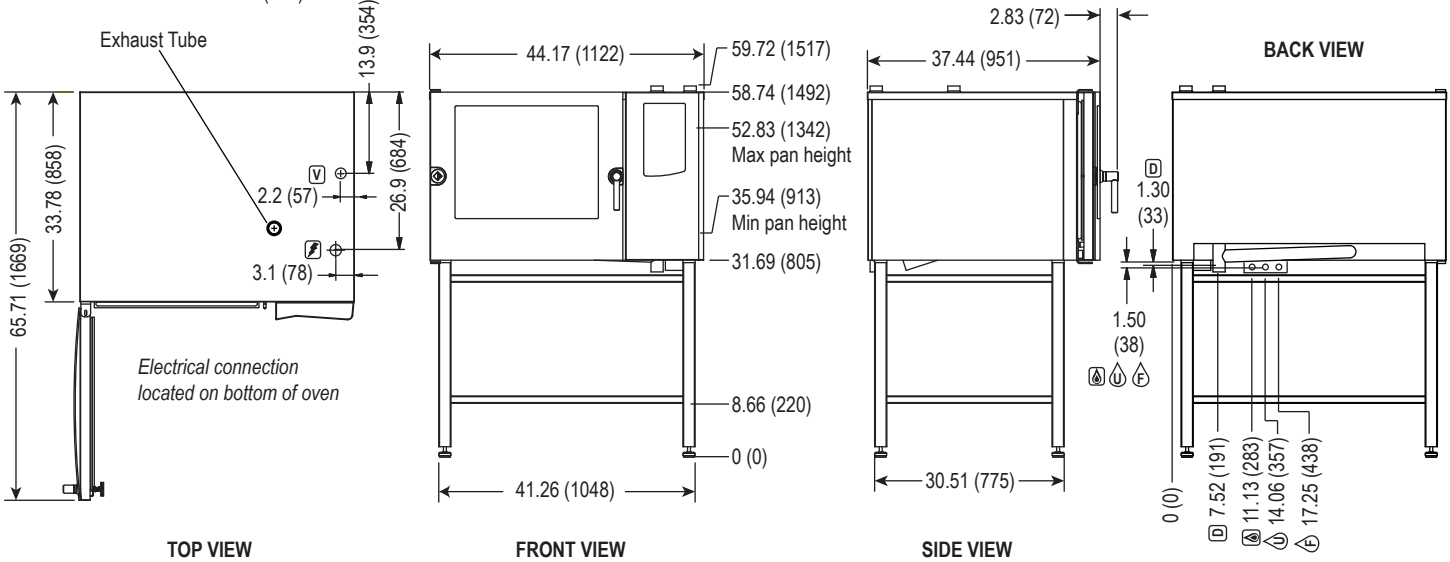

SHORT FORM SPECIFICATIONS: Provide Blodgett Combi model BLCM-62G combination-oven/steamer. The BLCM-62G has a pan cassette with 3.35" (85mm) spacing that holds five full size sheet pans or ten 12" x 20" x 2-1/2" deep North American hotel pans. The optional pan cassette with 2.5" (65mm) spacing that holds six 12" x 20" x 2" deep Gastronorm pans. Unit shall have 304 stainless steel exterior and interior. Oven door shall have dual pane tempered viewing window with hinged inner glass for easy cleaning. Multiple cooking modes include hot air, combi 1 (30-40% steam), combi 2 (60-80% steam), retherming, steaming, low-temperature steaming, and preheating. Unit shall have the ability to cook with pressureless steam, hot air, or combination of steam and hot air. Unit shall have steam injection system. Unit shall have bright halogen lights for superior visibility. Standard control includes user friendly digital display with dial, ability to store up to 50 recipe programs with 10 stages per recipe, and time delay start. The reversible 9 speed fan provides optimum baking and roasting results. Automated CombiWash, closed circuit cleaning system features very low water and detergent consumption and no contact with chemicals. One-year parts and labor warranty. Provide start-up inspection service by a factory authorized service agent. Provide options and accessories as indicated.

DIMENSIONS:

Floor space: 44.17" x 37.44" (1122 x 951mm)
Unit height:
 Oven on stand 58.74" (1492mm)
 Table model 31.30" (795mm)

OVEN CLEARANCES:

From combustible and non-combustible construction

Right 4" (102mm)
 Left 0" (0mm)
 Back 2" (50mm)

Blodgett recommends and 12" (305mm) be maintained on the control side for servicing.

MINIMUM ENTRY CLEARANCE:

Uncrated 33.78" (858mm)
 Crated 38" (965mm)

GAS SUPPLY (per section):

3/4" NPT

Inlet Pressure:

Natural 3.2-8.0" W.C. static to unit
 Propane 5.2-14" W.C. static to unit

Maximum Input:

81,800 BTU/hr

POWER SUPPLY:

115 VAC, 1 phase, 9 amps

Blodgett recommends a Pass & Seymour, model 2095, GFCI for this oven model due to the use of a variable frequency drive.

WATER SUPPLY & DRAIN:

Good quality water feed is the responsibility of the owner. Water quality must be within the following general guidelines.

TDS: 40-125 ppm Hardness: 35-100 ppm pH: 7.0 - 8.5 Silica: <13 ppm
 Chlorides: <25 ppm Pressure: 40(min)-50(max) PSI Chlorine: 0 ppm

The best defense against poor water quality is a water filter system designed to meet your water quality conditions. Blodgett offers optional water filters from Everpure and Terry Corp. for this unit.

Connections: 2" drain connection Max. drain temp. 140°F (60°C)
 3/4" garden hose cold water

Appliance is to be installed with backflow protection in accordance with Federal, State or Local codes.

SHIPPING INFORMATION:

Approx. weight: 540 lbs. (245 kg)

NOTE: The company reserves the right to make substitutions of components without prior notice

BLODGETT OVEN COMPANY

www.blodgett.com • 44 Lakeside Avenue, Burlington, VT 05401 • Phone: (802) 658-6600 • Fax: (802) 864-0183