



BLCT-23E

### BLCT-23E

Single Electric Mini Size  
Boilerless Combination-Oven/Steamer  
with Touchscreen Control

Project \_\_\_\_\_

Item No. \_\_\_\_\_

Quantity \_\_\_\_\_

- Standard 2 piece rack that holds six 2" deep or four 2-1/2" deep 2/3 size North American hotel pans

Refer to operator manual specification chart for listed model names.



#### CONSTRUCTION

- 304 stainless steel exterior and interior
- Dual pane tempered viewing window with hinged inner glass for easy cleaning
- 40mm (1.57") fixed drain in the bottom center of cavity
- Door mounted drip tray reduces the risk of wet, slippery floors
- Oven door with ventilated heat-reflecting glass
- CTD Cool Touch Door
- Left hinge door is field convertible to the right side (with the purchase of conversion kit)
- Two step safety door latch. The first step stops the fan.

#### OPERATION

- Injection steam system - water is injected onto the heating elements, the resulting steam is distributed in the oven chamber by the fan wheel.
- Automatic boiler flushing system
- Easy to use touchscreen control
- Multiple cooking modes include hot air, CombiSmart, CombiOptima, retherm, steaming, low-temperature steaming, forced steaming, proofing, preheating
- Stores up to 500 recipes with up to 15 steps each
- Manual or automatic cooling
- Automatic humidity pulsing
- External core temperature probe
- Rack timing allows for setting individual timers for each rack
- Reversible 9 speed fan for optimum baking and roasting results
- USB port for data and recipe transfer
- HACCP recording and documentation
- Automated CombiWash, closed circuit cleaning system features very low water and detergent consumption and no contact with chemicals. No proprietary chemicals required, see owner's manual for detergent guidelines.

#### OPTIONS AND ACCESSORIES

(AT ADDITIONAL CHARGE)

- Wire oven rack
- Optional stand for stacking
- Extra year warranty

#### STANDARD FEATURES

- Internal core temperature probe with multiple measuring points.
- Bright halogen lights for superior visibility
- Detachable hand shower
- Start-up inspection service by factory authorized service agent
- One year parts and labor oven warranty\*

\* For all international markets, contact your local distributor.



#### BLODGETT OVEN COMPANY

www.blodgett.com • 44 Lakeside Avenue, Burlington, VT 05401 • Phone: (802) 658-6600 • Fax: (802) 864-0183



# BLCT-23E



APPROVAL/STAMP

DIMENSIONS ARE IN INCHES (MM)

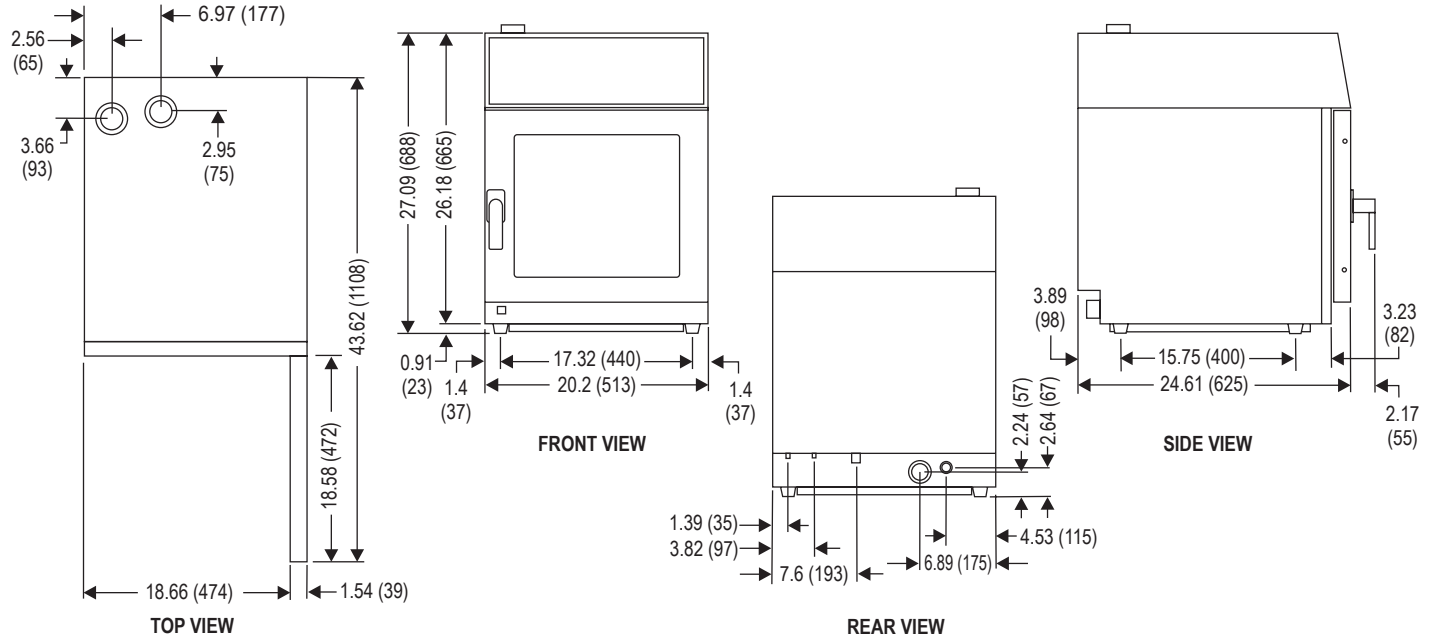

**SHORT FORM SPECIFICATIONS:** Provide Blodgett Combi model BLCT-23E mini boilerless combination-oven/steamer. The BLCT-23E has a 2 piece rack system that holds six 2" deep or four 2-1/2" deep 2/3 size North American hotel pans. Unit shall have 304 stainless steel exterior and interior. Oven door shall have dual pane tempered viewing window with hinged inner glass for easy cleaning. Unit shall have the ability to cook with pressureless steam, hot air, or combination of steam and hot air. Unit shall have steam injection system. Multiple modes include hot air, combi with CombiOptima, retherming, steaming, low-temperature steaming, forced steaming, proofing, cooling, and preheating. Unit shall have bright halogen lights for superior visibility. Touchscreen control stores 500 recipes with 15 stages each, in addition to pre-programmed recipes. External core temperature probe, rack timing allows for setting individual timers for each rack, HACCP quality control, USB connectivity, automatic service diagnosis. The reversible 9 speed fan provides optimum baking and roasting results. Automated CombiWash, closed circuit cleaning system features very low water and detergent consumption and no contact with chemicals. One-year parts and labor warranty. Provide start-up inspection service by a factory authorized service agent. Provide options and accessories as indicated.

## DIMENSIONS:

Floor space: 24.8" x 20.2" (630 x 515mm)  
 Unit height: 27.09" (672)

## OVEN CLEARANCES:

From combustible and non-combustible construction

Sides 2.75" (69.9mm)  
 Back 2.75" (69.9mm)  
 Top 19.5" (495mm)

Blodgett recommends 12" (305mm) be maintained on the control side for servicing.

## MINIMUM ENTRY CLEARANCE:

Uncrated 20.2" (513mm)  
 Crated 22.05" (560mm)

## POWER SUPPLY:

| Voltage     | Phase | KW          | Hz    | Amps |
|-------------|-------|-------------|-------|------|
| 208/230/240 | 1NAC  | 2.7/3.3/3.6 | 50/60 | 15   |
| 208/230/240 | 2AC   | 2.7/3.3/3.6 | 50/60 | 15   |
| 208/230/240 | 3AC   | 5.4/6.6/7.2 | 50/60 | 30   |
| 400/415     | 2NAC  | 6.6/7.2     | 50/60 | 15   |
| 400/415     | 2AC   | 5.4/5.8     | 50/60 | 15   |
| 440/480     | 2AC   | 5.4/6.5     | 50/60 | 15   |

## WATER SUPPLY & DRAIN:

**Water Supply:** Good quality water feed is the responsibility of the owner. Water quality must be within the following general guidelines.

TDS: < 100 ppm      Hardness: 80-120 ppm      pH: 7.0 - 8.0  
 Chlorides: < 30 ppm      Pressure: 30(min)-50(max) PSI      Chlorine: 0 ppm

3/4" hose cold water connection

The best defense against poor water quality is a water filter system designed to meet your water quality conditions. Blodgett offers an optional water filters from Everpure and Terry Corp. for this unit.

### Drain:

40mm (1.57") drain connection      Maximum drain temperature 140°F (60°C)  
 Appliance is to be installed with backflow protection in accordance with Federal, State or Local codes.

## SHIPPING INFORMATION:

Approx. weight: 144 lbs. (65 kg)  
 Crate size: 35.43" H x 22.05" W x 29.53" D (900 x 560 x 750mm)

**NOTE:** The company reserves the right to make substitutions of components without prior notice

## BLODGETT OVEN COMPANY

www.blodgett.com • 44 Lakeside Avenue, Burlington, VT 05401 • Phone: (802) 658-6600 • Fax: (802) 864-0183