

BNQT Series Queen Mary Banquet Cart

ITEM NO. _____

QUANTITY NO. _____

JOB NO. _____

SPEC NO. _____

SPECIFICATIONS:

- Multipurpose cart designed for storage and transportation of pots, pans, wire baskets, cups, and dishes.
- The frame is constructed of all welded 1½" x 1½" x 3/16" all welded reinforced aluminum. The shelves are constructed of heavy duty reinforced aluminum sheet. Standard configuration is 3 lips flanged up and front lip down. Other configurations are available upon request.
- A wrap around bumper protects walls, associates and equipment. Welded handle for easy maneuverability.
- Maneuvers on (2) 8" x 2" rigid and (2) 8" x 2" swivel polyurethane wheels with double race casters.



BNQT-5

LABORATORY CERTIFICATION AND APPROVAL
SYMBOLS:



439 Oak Street • Garden City, NY 11530 • Tel: 1-800-444-3595 • Fax: 516-222-0371
www.winholt.com • sales@winholt.com

NEW YORK • GEORGIA • TEXAS • CALIFORNIA

A City Discount

BNQT Series Queen Mary Banquet Cart

ITEM NO. _____

JOB NO. _____

SPEC NO. _____

Queen Mary Banquet Cart

BNQT Series Queen Mary Banquet Cart

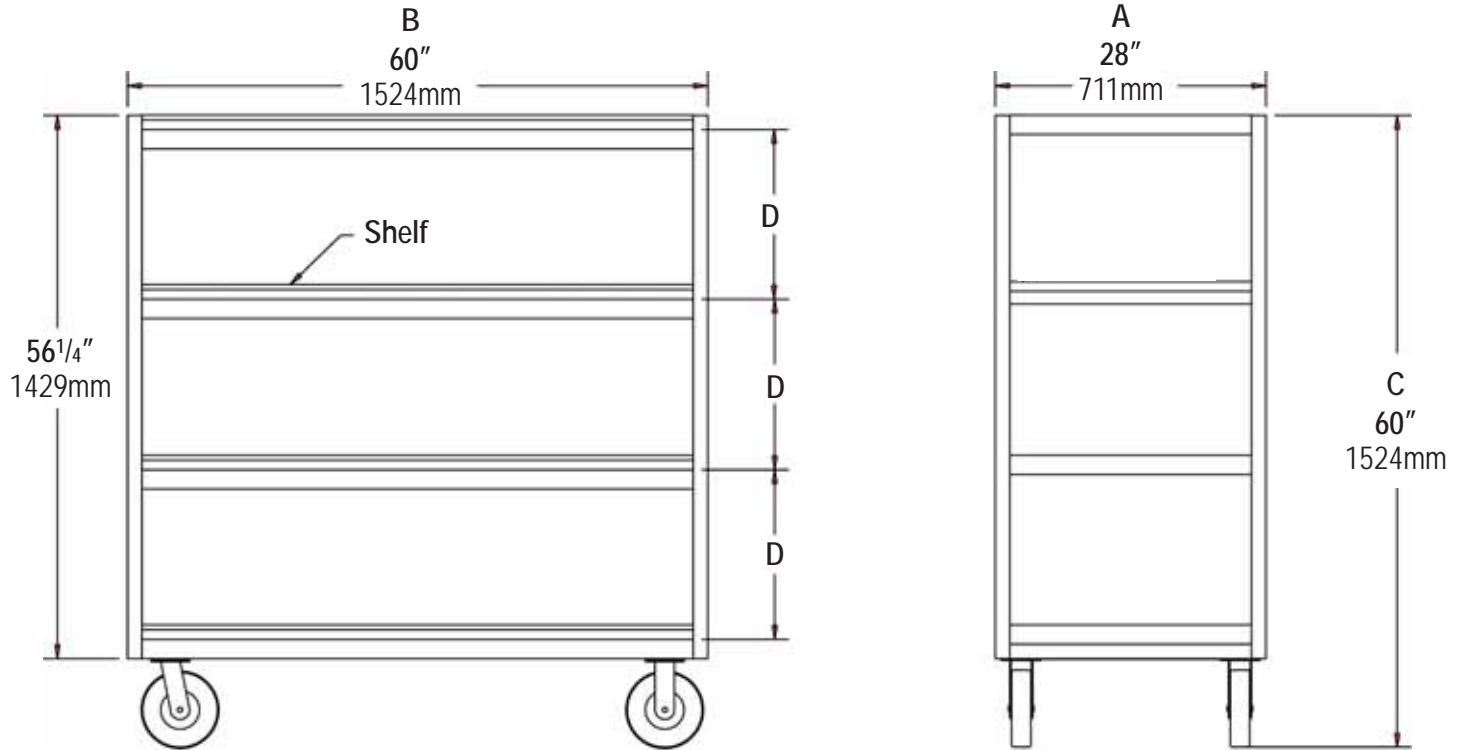

Model Number	Ordering Number	Overall Dimensions						# of Shelves	D		Approx. Ship Weight	
		A Width		B Length		C Height			Space Between Shelves			
		(in)	(mm)	(in)	(mm)	(in)	(mm)		(lb)	(kg)	(lb)	(kg)
Aluminum												
BNQT-3	154325	28	711	60	1,524	65 ⁷ / ₁₆	1,662	3	27	686	140	64
BNQT-4	127546							4	17 ¹⁹ / ₃₂	447	160	73
BNQT-5	112598							5	13 ¹ / ₂	343	180	82
Stainless Steel												
BNQT-3SS	232012	28	711	60	1,524	65 ⁷ / ₁₆	1,662	3	27	686	295	134
BNQT-4SS	168997							4	17 ¹⁹ / ₃₂	447	340	154
BNQT-5SS	232021							5	13 ¹ / ₂	343	385	174
Replacement Caster Information												
73161	123035	Swivel Plate Caster with 8" Mold-on Polyurethane Wheel									—	
7471	123537	Rigid Plate Caster with 8" Mold-on Polyurethane Wheel									—	
7116	122294	8" Mold-on Polyurethane Wheel									—	

Freight Class: 100

Win-Holt Equipment Group is a leading manufacturer of material & food handling equipment. Since 1946, retailers and restaurant chains have trusted Win-Holt's equipment to ensure increased productivity and efficiency in their operation. Multiple locations reduce logistics and transportation costs. All Win-Holt associates are dedicated to customer satisfaction.

For general sales and engineering information only. All units are subject to change without notice. Please consult factory for certified specifications.

439 Oak Street • Garden City, NY 11530 • Tel: 1-800-444-3595 • Fax: 516-222-0371

www.winholt.com • sales@winholt.com

NEW YORK • GEORGIA • TEXAS • CALIFORNIA

BNQT - 091304 - 2500

A City Discount