



a Standex company

Item _____

SELF-SERVE NON-REFRIGERATED BAKERY CASE MODEL BPDF-54SS



Generate increased bakery sales with maximum product exposure.

STANDARD FEATURES

- Self-closing clear acrylic lift-up doors.
- Clear acrylic ends.
- Front package shelf with bag holder and tissue dispenser.
- Choice of six standard laminates on base and package shelf. Other color laminates optional.
- Black interior and trim.
- Mirrored interior back.
- Top light.
- Two-tier, black wire shelves, slanted at a 10° angle.
- Storage area in lower base. Two-hinged doors.

BAKERY CASE

SELF-SERVE NON-REFRIGERATED

OPTIONAL ACCESSORIES:

- * Casters or Legs
- * Cord & Plug
- * Special Color Laminated Base
- * Mirrored Ends
- * Rear Sliding Glass Doors
- * Shelf Lights

PLAN VIEW

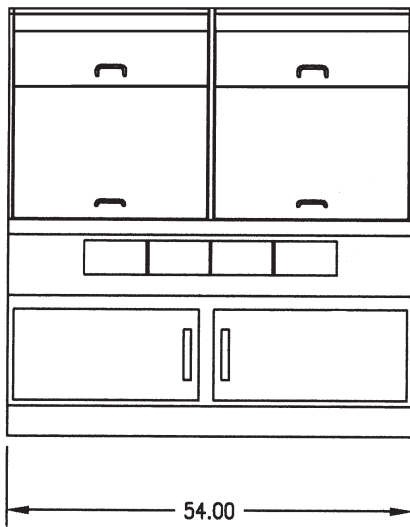
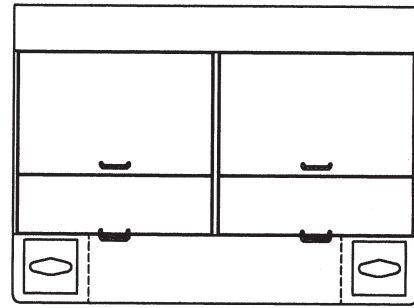

FRONT VIEW

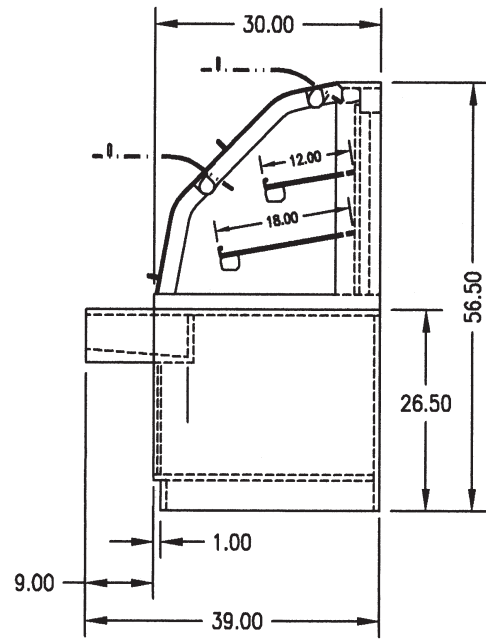

SIDE VIEW

SPECIFICATIONS:

Model	Dimensions			Shipping Weight (lbs)	Capacity (Bakery Pans)
	L	W	H		
BPFD-54SS	54"	39"	56 1/2"	750	6 (13" x 26")

- Electrical requirements for optional lights 120/60/1 - 2 AMPS.
- Due to continuing engineering improvements, specifications are subject to change without notice.



Look to Federal for Innovative Merchandising



a Standex company

Federal Industries
A Standex Company
215 Federal Avenue
Belleville WI 53508-0290
Phone: 800-356-4206
Fax: 608-424-3234
Email: geninfo@federalind.com
Web Site: www.federalind.com