

Short Form Specifications

Eagle Glass Froster, model _____. Foamed-in-place high density polyurethane insulation. Stainless steel countertop with 1/2" edge. Lockable stainless steel sliding cover(s) with extruded pull handles. Cabinet exterior features wear-resistant black vinyl. User-friendly well design allows easy reach to interior base. Removable interior shelving. Forced-air cooling. Factory balanced refrigeration system holds at 0°F. Automatic defrost system. Condensing system slides out for ease of maintenance. Split shelf design. 34 1/4" height.

Item #:	_____
Model #:	_____
Project #:	_____
SIS #:	_____

EG8186 Rev. 12/16

Design & Construction Features

- Stainless steel countertop with 1/2" upturn and lockable stainless steel sliding cover.
- Black vinyl-clad cabinet.
- Easy-to-reach large capacity well lined with painted aluminum interior.
- Removable perforated shelving inside cabinet.
- 1" extruded bumpers on rear of cabinet.
- Condenser unit slides out from behind front grill.
- 120-volt, 60-cycle, single-phase electricity
- 90" cord with NEMA 5-15P plug.
- Self-contained refrigeration holds temperature at 0°F.

New **Glass Frosters**
Nothing like a frosty mug!



model #BPR-GF-25 glass froster

There's nothing like a frosty mug for a cold drink. The stationary portion of the stainless steel top (with the 1/2" polymer edge) serves as a countertop, and features a lockable stainless steel easy-glide sliding cover. Cabinet exterior is wrapped in attractive yet durable black vinyl. The interior, lined with painted aluminum steel, is large yet user-friendly. A must for any facility utilizing commercial bar and beverage equipment.

For custom configuration or fabrication needs, contact our **SpecFAB**[®] Division.
 Phone: (302) 653-3000. FAX: (302) 653-2065.
 E-mail: quotes@eaglegrp.com

Glass Frosters

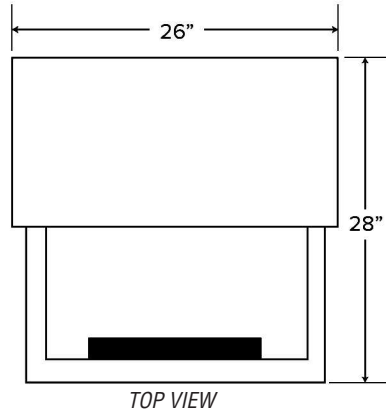

TOP VIEW

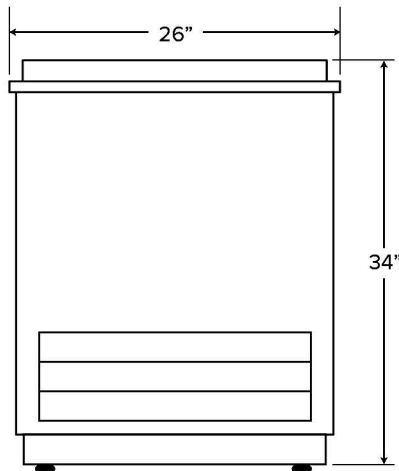

FRONT VIEW

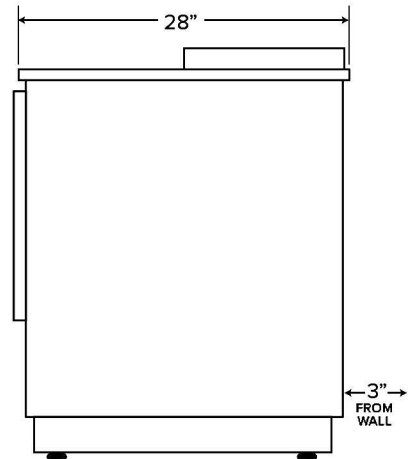

SIDE VIEW

(model #BPR-GF-25 shown)

width		length		height	# of sliding covers	capacities		electrical data	model #	NET price	
in.	mm	in.	mm	in.		mm	8" mugs				10" Steins
26 $\frac{3}{4}$ "	677	26 $\frac{3}{4}$ "	688	34 $\frac{1}{4}$ "	869	1	90	85	1/3-HP, 120V, 60-cycle, single-phase	BPR-GF-25	\$1388
26 $\frac{3}{4}$ "	677	49 $\frac{1}{2}$ "	1257	34 $\frac{1}{4}$ "	869	2	250	240	1/3-HP, 120V, 60-cycle, single-phase*	BPR-GF-50	1722

* #BPR-GF-50 also available for 230-240V/50/1 operation.