

Specification Sheet

Short Form Specifications

BLENDPORT worktables, Deluxe series, model _____, Top constructed of 16 gauge 300 series stainless steel with 1½" roll on front and rear, and sides turned down 90°. Undershef is adjustable and constructed of heavy gauge galvanized. Top reinforced with welded hat channels, and sound deadened. Constructed with uni-lok® patented gusset system with the gussets recessed into the hat channels to reduce lateral movement. Legs are 1½" O.D. galvanized tubing with galvanized gussets, and 1" hi-impact plastic bullet feet.



worktable with flat top and undershef

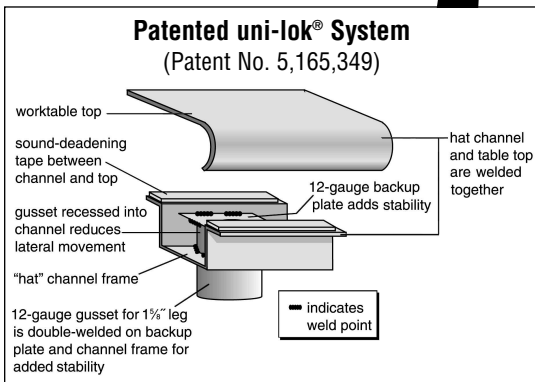

Patented uni-lok® System (Patent No. 5,165,349)

Item No.: _____
Project No.: _____
S.I.S. No.: _____

Worktables with Flat Top and Galvanized Base with Adjustable Undershef—Deluxe Series

MODELS:

- | | | |
|-------------------------------------|-------------------------------------|-------------------------------------|
| <input type="checkbox"/> BPT-2424EB | <input type="checkbox"/> BPT-3024EB | <input type="checkbox"/> BPT-3096EB |
| <input type="checkbox"/> BPT-2430EB | <input type="checkbox"/> BPT-3030EB | <input type="checkbox"/> BPT-3636EB |
| <input type="checkbox"/> BPT-2436EB | <input type="checkbox"/> BPT-3036EB | <input type="checkbox"/> BPT-3648EB |
| <input type="checkbox"/> BPT-2448EB | <input type="checkbox"/> BPT-3048EB | <input type="checkbox"/> BPT-3660EB |
| <input type="checkbox"/> BPT-2460EB | <input type="checkbox"/> BPT-3060EB | <input type="checkbox"/> BPT-3672EB |
| <input type="checkbox"/> BPT-2472EB | <input type="checkbox"/> BPT-3072EB | <input type="checkbox"/> BPT-3684EB |
| <input type="checkbox"/> BPT-2484EB | <input type="checkbox"/> BPT-3084EB | <input type="checkbox"/> BPT-3696EB |
| <input type="checkbox"/> BPT-2496EB | | |

Tabletop

- Patented uni-lok® gusset system (patent #5,165,349): gussets are recessed into hat channel, reducing lateral movement.
- Top reinforced with welded-on hat channel.
- Sound-deadened between top and channels.
- 1½" (38mm)-diameter 180° rolled edges on front and rear. Ends are turned down 90° providing for flush installations when required.
- 16 gauge 300 series polished stainless steel.

Adjustable Undershef

- Heavy gauge, galvanized.
- Gusset welded to each corner.

Legs—1½" (41mm)-diameter

- Tables 96" (2438mm) and longer come with six legs or more.
- Heavy gauge galvanized steel.
- 1" (25mm) adjustable hi-impact plastic feet.

Options / Accessories

- | | |
|--|--|
| <input type="checkbox"/> Drawer | <input type="checkbox"/> Duplex receptacles |
| <input type="checkbox"/> Lock | <input type="checkbox"/> Pot rack |
| <input type="checkbox"/> Casters | <input type="checkbox"/> Sink |
| <input type="checkbox"/> Stainless steel bullet feet | <input type="checkbox"/> Additional undershef |
| <input type="checkbox"/> Overshelves | <input type="checkbox"/> Stabilizer Bar (for 30"- and 36"-wide tables) |

Item No.: _____
 Project No.: _____
 S.I.S. No.: _____

Worktables with Flat Top and Galvanized Base with Adjustable Undershef—Deluxe Series

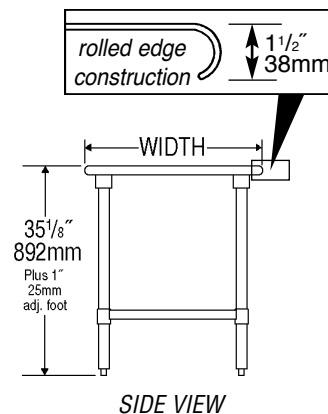
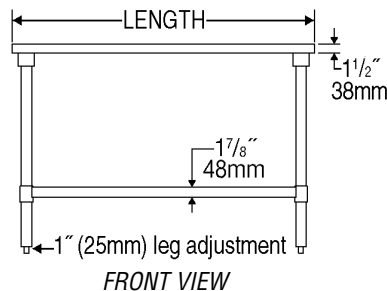
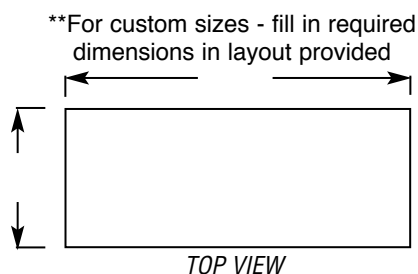

model #	# of legs	width		length		weight	
		in.	mm	in.	mm	lbs.	kg
BPT-2424EB	4	24"	610	24"	610	40	18.1
BPT-2430EB	4	24"	610	30"	762	45	20.4
BPT-2436EB	4	24"	610	36"	914	50	22.7
BPT-2448EB	4	24"	610	48"	1219	60	27.2
BPT-2460EB	4	24"	610	60"	1524	70	31.8
BPT-2472EB	4	24"	610	72"	1829	80	36.3
BPT-2484EB	4	24"	610	84"	2134	90	40.8
BPT-2496EB	6	24"	610	96"	2438	100	45.4
BPT-3024EB	4	30"	762	24"	610	45	20.4
BPT-3030EB	4	30"	762	30"	762	46	20.9
BPT-3036EB	4	30"	762	36"	914	52	23.6
BPT-3048EB	4	30"	762	48"	1219	64	29.0
BPT-3060EB	4	30"	762	60"	1524	76	34.5
BPT-3072EB	4	30"	762	72"	1829	84	38.1
BPT-3084EB	4	30"	762	84"	2134	96	43.6
BPT-3096EB	6	30"	762	96"	2438	108	49.0
BPT-3636EB	4	36"	914	36"	914	60	27.2
BPT-3648EB	4	36"	914	48"	1219	70	31.8
BPT-3660EB	4	36"	914	60"	1524	82	37.2
BPT-3672EB	4	36"	914	72"	1829	96	43.6
BPT-3684EB	4	36"	914	84"	2134	108	49.0
BPT-3696EB	6	36"	914	96"	2438	120	54.4
BPT-36108EB	6	36"	914	108"	2743	132	59.9
BPT-36120EB	6	36"	914	120"	3048	144	65.3
BPT-36132EB	8	36"	914	132"	3353	156	70.8
BPT-36144EB	8	36"	914	144"	3658	168	76.2

BlendPort®

An Eagle Group Company
 100 Industrial Boulevard, Clayton, DE 19938-8903 USA
 Phone: 800-441-8440 • Fax: 302-653-2065

Printed in U.S.A.
 ©2018 by Eagle Group
 Rev. 09/18

Although every attempt has been made to ensure the accuracy of the information provided, we cannot be held responsible for typographical or printing errors. Information and specifications are subject to change without notice. Please confirm at time of order.