

# Specification Sheet

## Short Form Specifications

Blendport worktables, Budget series, model \_\_\_\_\_.  
Top constructed of heavy gauge type 430 stainless steel with 1½" roll on front, 4½" backsplash, and sides turned down 90°. Adjustable undershelf constructed of heavy gauge type 430 stainless steel with marine edge. Top reinforced with hat channels and sound deadened. Constructed with uni-lok® patented gusset system with the gussets recessed to reduce lateral movement. 1½"-diameter stainless steel legs, with galvanized gussets and 1" stainless steel adjustable bullet feet.



*worktable with backsplash and adjustable undershelf*

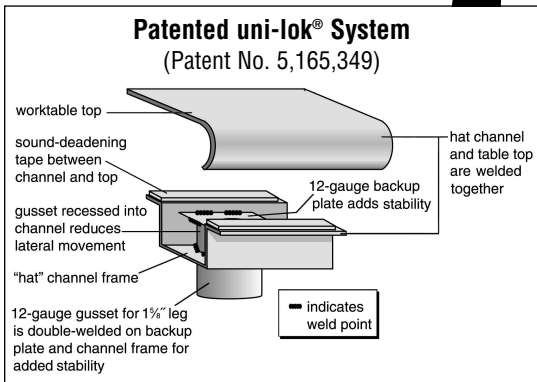

Item No.: \_\_\_\_\_  
Project No.: \_\_\_\_\_  
S.I.S. No.: \_\_\_\_\_

## Worktables with Backsplash and Stainless Steel Base with Undershelf —Budget Series

### MODELS:

- |  |  |
|--|--|
| <input type="checkbox"/> BPT-2424SB-BS | <input type="checkbox"/> BPT-3024SB-BS |
| <input type="checkbox"/> BPT-2430SB-BS | <input type="checkbox"/> BPT-3030SB-BS |
| <input type="checkbox"/> BPT-2436SB-BS | <input type="checkbox"/> BPT-3036SB-BS |
| <input type="checkbox"/> BPT-2448SB-BS | <input type="checkbox"/> BPT-3048SB-BS |
| <input type="checkbox"/> BPT-2460SB-BS | <input type="checkbox"/> BPT-3060SB-BS |
| <input type="checkbox"/> BPT-2472SB-BS | <input type="checkbox"/> BPT-3072SB-BS |
| <input type="checkbox"/> BPT-2484SB-BS | <input type="checkbox"/> BPT-3084SB-BS |
| <input type="checkbox"/> BPT-2496SB-BS | <input type="checkbox"/> BPT-3096SB-BS |

### Tabletop

- Patented uni-lok® gusset system (patent #5,165,349): gussets are recessed into hat channel, reducing lateral movement.
- Top reinforced with welded-on hat channel.
- Sound-deadened between top and channels.
- 4½" (114mm)-high 90° backsplash with 1" (25mm) turn at 90°.
- 1½" (38mm)-diameter 180° rolled edge on front. Ends are turned down 90°, providing for flush installations when required.
- Heavy gauge type 430 polished stainless steel.

### Adjustable Undershelf

- Heavy gauge stainless steel.
- Gusset welded to each corner.
- Heavy duty marine edge design.

### Legs—1½" (41mm)-diameter

- Tables 96" (2438mm) and longer come with six legs or more.
- Heavy gauge stainless steel.
- 1" (25mm) adjustable stainless steel feet.

### Options / Accessories

- |  |  |
|--|--|
| <input type="checkbox"/> Drawer                              | <input type="checkbox"/> Duplex receptacles                            |
| <input type="checkbox"/> Lock                                | <input type="checkbox"/> Pot rack                                      |
| <input type="checkbox"/> Casters                             | <input type="checkbox"/> Sink  |
| <input type="checkbox"/> Stainless steel bullet feet         | <input type="checkbox"/> Additional undershelf                         |
| <input type="checkbox"/> Overshelves                         | <input type="checkbox"/> Stabilizer Bar (for 30"- and 36"-wide tables) |
| <input type="checkbox"/> Power strip (for material handling) |  |





Item No.:	_____
Project No.:	_____
S.I.S. No.:	_____

## Worktables with Backsplash and Stainless Steel Base with Undershef—Budget Series

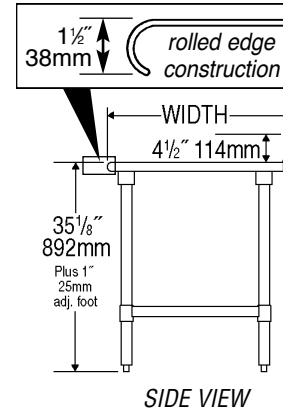
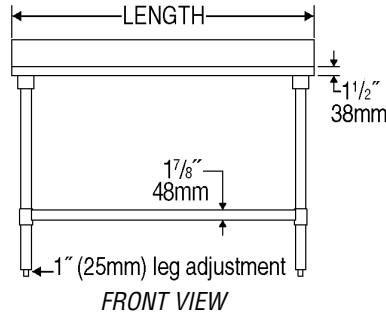
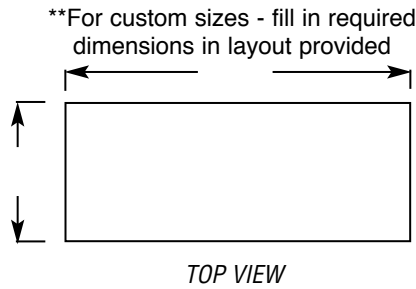

model #	# of legs	width		length		weight	
		in.	mm	in.	mm	lbs.	kg
<i>BPT-2424SB-BS</i>	4	24"	610	24"	610	43	19.5
<i>BPT-2430SB-BS</i>	4	24"	610	30"	762	48	21.8
<i>BPT-2436SB-BS</i>	4	24"	610	36"	914	53	24.0
<i>BPT-2448SB-BS</i>	4	24"	610	48"	1219	63	28.6
<i>BPT-2460SB-BS</i>	4	24"	610	60"	1524	73	33.1
<i>BPT-2472SB-BS</i>	4	24"	610	72"	1829	85	38.6
<i>BPT-2484SB-BS</i>	4	24"	610	84"	2134	97	44.0
<i>BPT-2496SB-BS</i>	6	24"	610	96"	2438	114	51.7
<i>BPT-3024SB-BS</i>	4	30"	762	24"	610	45	20.4
<i>BPT-3030SB-BS</i>	4	30"	762	30"	762	50	22.7
<i>BPT-3036SB-BS</i>	4	30"	762	36"	914	53	24.0
<i>BPT-3048SB-BS</i>	4	30"	762	48"	1219	70	31.8
<i>BPT-3060SB-BS</i>	4	30"	762	60"	1524	81	36.7
<i>BPT-3072SB-BS</i>	4	30"	762	72"	1829	94	42.6
<i>BPT-3084SB-BS</i>	4	30"	762	84"	2134	108	49.0
<i>BPT-3096SB-BS</i>	6	30"	762	96"	2438	130	59.0

### BlendPort®

An Eagle Group Company  
 100 Industrial Boulevard, Clayton, DE 19938-8903 USA  
 Phone: 800-441-8440 • Fax: 302-653-2065

Printed in U.S.A.  
 ©2018 by Eagle Group  
 Rev. 09/18

Although every attempt has been made to ensure the accuracy of the information provided, we cannot be held responsible for typographical or printing errors. Information and specifications are subject to change without notice. Please confirm at time of order.