

Specification Sheet

Short Form Specifications

Blendport worktables, Budget series model _____.
Top constructed of heavy gauge type 430 stainless steel with 1½" roll on front, 1½" rear upturn, and sides turned down 90°. Open front with 1¼" O.D. galvanized tubular crossbracing on sides and rear. Top reinforced with hat channels and sound deadened. Constructed with uni-lok® patented gusset system with the gussets recessed into the hat channels to reduce lateral movement. Legs are 1½" O.D. galvanized tubing with galvanized gussets and 1" hi-impact plastic bullet feet.



worktable with upturn and tubular base

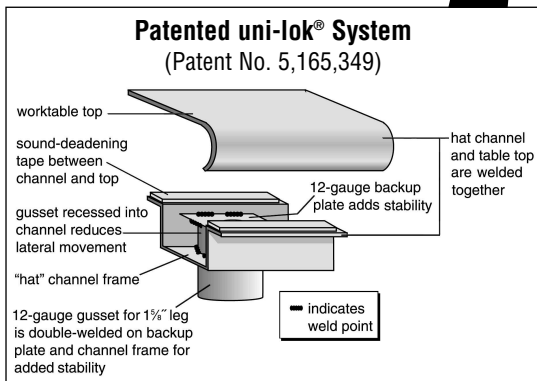

Item No.: _____
Project No.: _____
S.I.S. No.: _____

Worktables with Rear Upturn and Galvanized Tubular Base —Budget Series

MODELS:

- | | | |
|---|---|---|
| <input type="checkbox"/> BPT-2424GTB-UT | <input type="checkbox"/> BPT-3024GTB-UT | <input type="checkbox"/> BPT-3636GTB-UT |
| <input type="checkbox"/> BPT-2430GTB-UT | <input type="checkbox"/> BPT-3030GTB-UT | <input type="checkbox"/> BPT-3648GTB-UT |
| <input type="checkbox"/> BPT-2436GTB-UT | <input type="checkbox"/> BPT-3036GTB-UT | <input type="checkbox"/> BPT-3660GTB-UT |
| <input type="checkbox"/> BPT-2448GTB-UT | <input type="checkbox"/> BPT-3048GTB-UT | <input type="checkbox"/> BPT-3672GTB-UT |
| <input type="checkbox"/> BPT-2460GTB-UT | <input type="checkbox"/> BPT-3060GTB-UT | <input type="checkbox"/> BPT-3684GTB-UT |
| <input type="checkbox"/> BPT-2472GTB-UT | <input type="checkbox"/> BPT-3072GTB-UT | <input type="checkbox"/> BPT-3696GTB-UT |
| <input type="checkbox"/> BPT-2484GTB-UT | <input type="checkbox"/> BPT-3084GTB-UT | |
| <input type="checkbox"/> BPT-2496GTB-UT | <input type="checkbox"/> BPT-3096GTB-UT | |

Tabletop

- Top reinforced with welded-on hat channel.
- Sound-deadened between top and channels.
- 1½" (38mm) 90° rear upturn with radius at intersection.
- 1½" (38mm)-diameter 180° rolled edge on front. Ends are turned down 90°, providing for flush installations when required.
- 16 gauge type 430 polished stainless steel.

Crossbracing—1¼" (38mm)-diameter

- Heavy gauge, galvanized.
- Aluminum castings join rear and side crossbraces with legs.

Legs—1½" (41mm)-diameter

- Units 96" to 120" (2438 to 3048mm) long come with six legs; Units 132" and 144" (3353 and 3658mm) come with eight legs.
- Patented uni-lok® gusset system (patent #5,165,349) is recessed into channel, reducing lateral movement.
- Heavy gauge galvanized steel.
- Galvanized gussets.
- 1" (25mm) adjustable hi-impact plastic feet.

Options / Accessories

- | | |
|--|---|
| <input type="checkbox"/> Drawer | <input type="checkbox"/> Duplex receptacles |
| <input type="checkbox"/> Lock | <input type="checkbox"/> Pot rack |
| <input type="checkbox"/> Casters | <input type="checkbox"/> Sink |
| <input type="checkbox"/> Stainless steel bullet feet | <input type="checkbox"/> Additional undershelf |
| <input type="checkbox"/> Stainless steel gussets | <input type="checkbox"/> Stabilizer Bar (for 30" and 36"-wide tables) |
| <input type="checkbox"/> Overshelves | |

Item No.:	_____
Project No.:	_____
S.I.S. No.:	_____

Worktables with Rear Uprturn and Galvanized Tubular Base —Budget Series

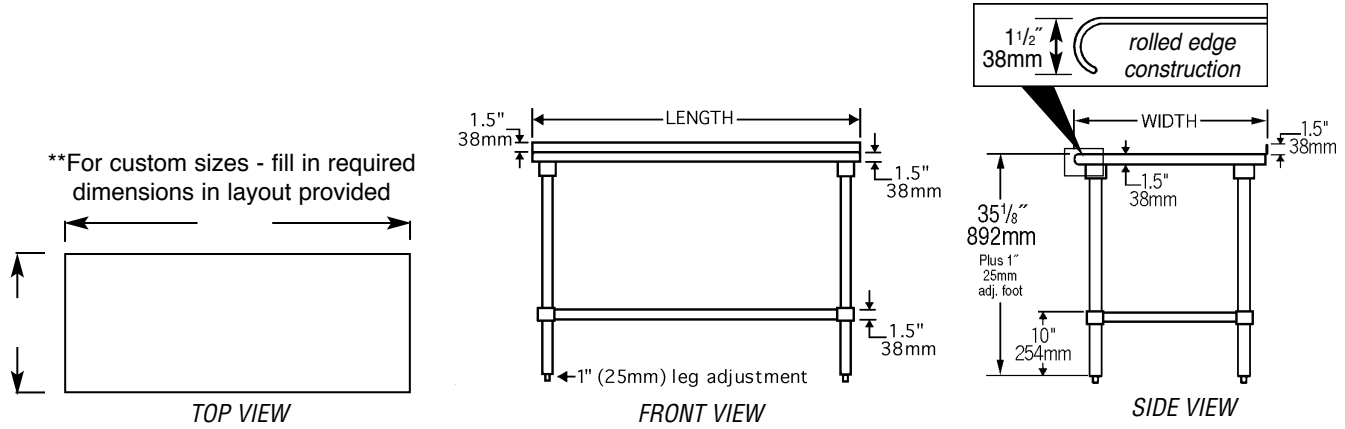

model #	# of legs	width		length		weight	
		in.	mm	in.	mm	lbs.	kg
BPT-2424GTB-UT	4	24"	610	24"	610	40	18.1
BPT-2430GTB-UT	4	24"	610	30"	762	45	20.4
BPT-2436GTB-UT	4	24"	610	36"	914	50	22.7
BPT-2448GTB-UT	4	24"	610	48"	1219	60	27.2
BPT-2460GTB-UT	4	24"	610	60"	1524	70	31.8
BPT-2472GTB-UT	4	24"	610	72"	1829	80	36.3
BPT-2484GTB-UT	4	24"	610	84"	2134	90	40.8
BPT-2496GTB-UT	6	24"	610	96"	2438	100	45.4
BPT-3024GTB-UT	4	30"	762	24"	610	45	20.4
BPT-3030GTB-UT	4	30"	762	30"	762	50	22.7
BPT-3036GTB-UT	4	30"	762	36"	914	53	24.0
BPT-3048GTB-UT	4	30"	762	48"	1219	57	25.9
BPT-3060GTB-UT	4	30"	762	60"	1524	67	30.4
BPT-3072GTB-UT	4	30"	762	72"	1829	77	34.9
BPT-3084GTB-UT	4	30"	762	84"	2134	87	39.5
BPT-3096GTB-UT	6	30"	762	96"	2438	97	44.0
BPT-3636GTB-UT	4	36"	914	36"	914	60	27.2
BPT-3648GTB-UT	4	36"	914	48"	1219	61	27.7
BPT-3660GTB-UT	4	36"	914	60"	1524	72	32.7
BPT-3672GTB-UT	4	36"	914	72"	1829	85	38.6
BPT-3684GTB-UT	4	36"	914	84"	2134	97	44.0
BPT-3696GTB-UT	6	36"	914	96"	2438	109	49.4