

Specification Sheet

Short Form Specifications

Blendport worktables, Deluxe series, model _____.
Top constructed of 16 gauge 300 series stainless steel with 1½" roll on front, 1½" rear upturn, and sides turned down 90°. Undershef is adjustable and constructed of heavy gauge type 430 stainless steel with marine edge. Top reinforced with hat channels and sound deadened. Constructed with uni-lok® patented gusset system with the gussets recessed into the hat channels to reduce lateral movement. Legs are 1½" O.D., stainless steel, with galvanized gussets and 1" stainless steel adjustable bullet feet.



worktable with upturn and adjustable undershef

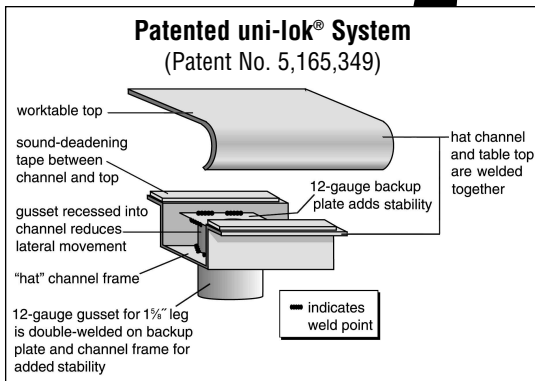

Options / Accessories

- Drawer
- Lock
- Casters
- Stainless steel bullet feet
- Overshelves
- Duplex receptacles
- Pot rack
- Sink
- Additional undershef
- Stabilizer Bar (for 30"- and 36"-wide tables)

BlendPort®
An Eagle Group Company
100 Industrial Boulevard, Clayton, DE 19938-8903 USA
Phone: 800-441-8440 • Fax: 302-653-2065

Item No.: _____
Project No.: _____
S.I.S. No.: _____

Worktables with Rear Upturn and Stainless Steel Base with Adjustable Undershef —Deluxe Series

MODELS:

- | | | |
|---|---|---|
| <input type="checkbox"/> BPT-2424SEB-UT | <input type="checkbox"/> BPT-3024SEB-UT | <input type="checkbox"/> BPT-3636SEB-UT |
| <input type="checkbox"/> BPT-2430SEB-UT | <input type="checkbox"/> BPT-3030SEB-UT | <input type="checkbox"/> BPT-3648SEB-UT |
| <input type="checkbox"/> BPT-2436SEB-UT | <input type="checkbox"/> BPT-3036SEB-UT | <input type="checkbox"/> BPT-3660SEB-UT |
| <input type="checkbox"/> BPT-2448SEB-UT | <input type="checkbox"/> BPT-3048SEB-UT | <input type="checkbox"/> BPT-3672SEB-UT |
| <input type="checkbox"/> BPT-2460SEB-UT | <input type="checkbox"/> BPT-3060SEB-UT | <input type="checkbox"/> BPT-3684SEB-UT |
| <input type="checkbox"/> BPT-2472SEB-UT | <input type="checkbox"/> BPT-3072SEB-UT | <input type="checkbox"/> BPT-3696SEB-UT |
| <input type="checkbox"/> BPT-2484SEB-UT | <input type="checkbox"/> BPT-3084SEB-UT | |
| <input type="checkbox"/> BPT-2496SEB-UT | <input type="checkbox"/> BPT-3096SEB-UT | |

Tabletop

- Patented uni-lok® gusset system (patent #5,165,349): gussets are recessed into hat channel, reducing lateral movement.
- Top reinforced with welded-on hat channel.
- Sound-deadened between top and channels.
- 1½" (38mm) 90° rear upturn with radius at intersection.
- 1½" (41mm)-diameter 180° rolled edge on front. Ends are turned down 90° providing for flush installations when required.
- 16 gauge 300 series polished stainless steel.

Adjustable Undershef

- Heavy gauge stainless steel.
- Gusset welded on each corner.
- Heavy duty marine edge.

Legs—1½" (41mm)-diameter

- Units 96" to 120" (2438 to 3048mm) long come with six legs; Units 132" and 144" (3353 and 3658mm) come with eight legs.
- Heavy gauge stainless steel.
- 1" (25mm) adjustable stainless steel feet.

Certifications / Approvals





Item No.: _____
 Project No.: _____
 S.I.S. No.: _____

Worktables with Rear Upturn and Stainless Steel Base with Adjustable Undershef—Deluxe Series

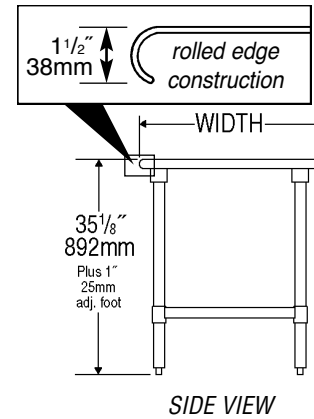
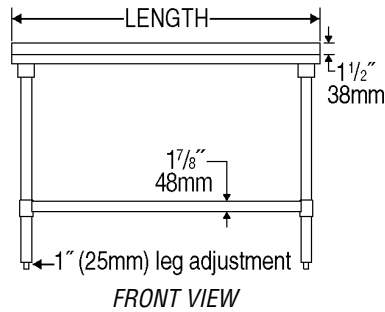
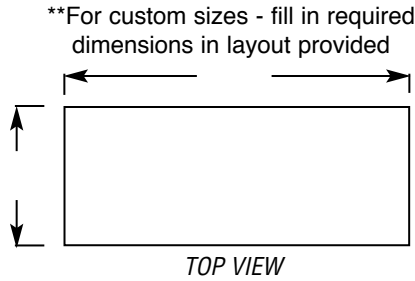

model #	# of legs	width		length		weight	
		in.	mm	in.	mm	lbs.	kg
BPT-2424SEB-UT	4	24"	610	24"	610	40	18.1
BPT-2430SEB-UT	4	24"	610	30"	762	45	20.4
BPT-2436SEB-UT	4	24"	610	36"	914	50	22.7
BPT-2448SEB-UT	4	24"	610	48"	1219	60	27.2
BPT-2460SEB-UT	4	24"	610	60"	1524	70	31.8
BPT-2472SEB-UT	4	24"	610	72"	1829	80	36.3
BPT-2484SEB-UT	4	24"	610	84"	2134	90	40.8
BPT-2496SEB-UT	6	24"	610	96"	2438	100	45.4
BPT-3024SEB-UT	4	30"	762	24"	610	45	20.4
BPT-3030SEB-UT	4	30"	762	30"	762	50	22.7
BPT-3036SEB-UT	4	30"	762	36"	914	55	24.9
BPT-3048SEB-UT	4	30"	762	48"	1219	65	29.5
BPT-3060SEB-UT	4	30"	762	60"	1524	75	34.0
BPT-3072SEB-UT	4	30"	762	72"	1829	85	38.6
BPT-3084SEB-UT	4	30"	762	84"	2134	95	43.1
BPT-3096SEB-UT	6	30"	762	96"	2438	105	47.6
BPT-3636SEB-UT	4	36"	914	36"	914	60	27.2
BPT-3648SEB-UT	4	36"	914	48"	1219	75	34.0
BPT-3660SEB-UT	4	36"	914	60"	1524	85	36.8
BPT-3672SEB-UT	4	36"	914	72"	1829	95	43.1
BPT-3684SEB-UT	4	36"	914	84"	2134	105	47.6
BPT-3696SEB-UT	6	36"	914	96"	2438	115	52.2

BlendPort®

An Eagle Group Company
 100 Industrial Boulevard, Clayton, DE 19938-8903 USA
 Phone: 800-441-8440 • Fax: 302-653-2065

Printed in U.S.A.
 ©2018 by Eagle Group
 Rev. 09/18

Although every attempt has been made to ensure the accuracy of the information provided, we cannot be held responsible for typographical or printing errors. Information and specifications are subject to change without notice. Please confirm at time of order.