

Item No.:	_____	Qty.:	_____
Model No.:	_____		
Project No.:	_____		

### Budget Series Work Table

*Budget Work Table, Backsplash with Galvanized Undershef*



24"

30"

36"

- |                                       |                                       |                                       |
|---------------------------------------|---------------------------------------|---------------------------------------|
| <input type="checkbox"/> BWT24S36-BG  | <input type="checkbox"/> BWT30S30-BG  | <input type="checkbox"/> BWT36S36-BG  |
| <input type="checkbox"/> BWT24S48-BG  | <input type="checkbox"/> BWT30S36-BG  | <input type="checkbox"/> BWT36S48-BG  |
| <input type="checkbox"/> BWT24S60-BG  | <input type="checkbox"/> BWT30S48-BG  | <input type="checkbox"/> BWT36S60-BG  |
| <input type="checkbox"/> BWT24S72-BG  | <input type="checkbox"/> BWT30S60-BG  | <input type="checkbox"/> BWT36S72-BG  |
| <input type="checkbox"/> BWT24S84-BG  | <input type="checkbox"/> BWT30S72-BG  | <input type="checkbox"/> BWT36S84-BG  |
| <input type="checkbox"/> BWT24S96-BG  | <input type="checkbox"/> BWT30S84-BG  | <input type="checkbox"/> BWT36S96-BG  |
| <input type="checkbox"/> BWT24S108-BG | <input type="checkbox"/> BWT30S96-BG  | <input type="checkbox"/> BWT36S108-BG |
| <input type="checkbox"/> BWT24S120-BG | <input type="checkbox"/> BWT30S108-BG | <input type="checkbox"/> BWT36S120-BG |
|                                       | <input type="checkbox"/> BWT30S120-BG |                                       |

### Features

- 16 Gauge, 400 series stainless steel
- 4" Backsplash with 1" return
- Welded construction for consistent metal gauge thickness throughout
- Sound deadened between top and bottom hat channels with double sided tape
- 1-5/8" Galvanized legs with high impact plastic feet, adjustable up to 1"
- Fully adjustable galvanized undershef
- Shipped knocked down for reduced shipping costs and supplied with Allen wrench and screws

### Options

- Custom Size / Height
- Cutout in Top (depending on size and location)
- Edge Modification
- Urn Trough
- Overshelves
- Undershelves
- Drawers
- Sink
- Splash
- Base Options
- Welded Set-Up
- Casters / Feet Upgrade

\* For additional available options, contact Elkay SSP

### Materials

- **Top:** 16 Gauge, 400 series stainless steel, 1-3/4" turned-down edge
- **Legs:** 1-5/8" Diameter heavy gauge galvanized tubing with galvanized leg gussets and high impact plastic feet, adjustable up to 1"
- **Undershef:** Galvanized steel with 1-1/2" turned-down edge, fully adjustable



**AUTOQUOTES**



*In keeping with our policy of continuing product improvement, Elkay SSP reserves the right to change product specifications without notice.*

*This specification describes an Elkay SSP product with design, quality and functional benefits to the user. When making a comparison of other producers' offerings, be certain these features are not overlooked.*

#### Elkay SSP

421 N. Freya St.  
Spokane, WA 99205  
Phone: 800-726-0553 Fax: 509-535-1493

Website: [www.sspinc.net](http://www.sspinc.net)  
Email: [sspsales@elkay.com](mailto:sspsales@elkay.com)  
©2011 Elkay



Item No.: \_\_\_\_\_ Qty.: \_\_\_\_\_  
 Model No.: \_\_\_\_\_  
 Project No.: \_\_\_\_\_

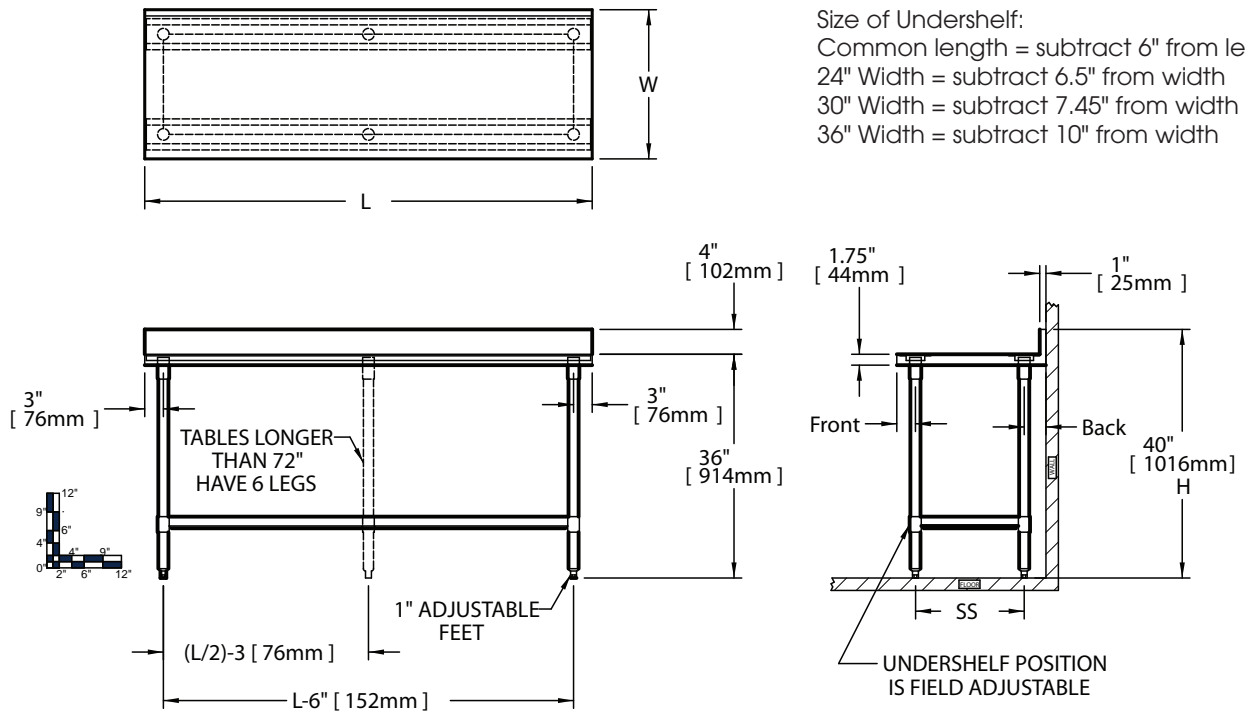

Size of Undershef:  
 Common length = subtract 6" from length  
 24" Width = subtract 6.5" from width  
 30" Width = subtract 7.45" from width  
 36" Width = subtract 10" from width

24" Work Table				30" Work Table				36" Work Table				Legs			
Model Number	Overall Size		Weight	Model Number	Overall Size		Weight	Model Number	Overall Size		Weight				
	Length L	Height H			Length L	Height H			Length L	Height H					
	in.	mm	lbs.   kg		in.	mm	lbs.   kg		in.	mm	lbs.   kg				
				BWT 30 S 30 - BG	30	762	40   1016	100   45					4		
BWT 24 S 36 - BG	36	914	40   1016	101   46	BWT 30 S 36 - BG	36	914	40   1016	113   51	BWT 36 S 36 - BG	36	914	40   1016	128   58	4
BWT 24 S 48 - BG	48	1219	40   1016	123   56	BWT 30 S 48 - BG	48	1219	40   1016	137   62	BWT 36 S 48 - BG	48	1219	40   1016	156   71	4
BWT 24 S 60 - BG	60	1524	40   1016	150   68	BWT 30 S 60 - BG	60	1524	40   1016	166   75	BWT 36 S 60 - BG	60	1524	40   1016	191   87	4
BWT 24 S 72 - BG	72	1829	40   1016	172   78	BWT 30 S 72 - BG	72	1829	40   1016	191   87	BWT 36 S 72 - BG	72	1829	40   1016	219   100	4
BWT 24 S 84 - BG	84	2134	40   1016	209   95	BWT 30 S 84 - BG	84	2134	40   1016	231   105	BWT 36 S 84 - BG	84	2134	40   1016	264   120	6
BWT 24 S 96 - BG	96	2438	40   1016	232   105	BWT 30 S 96 - BG	96	2438	40   1016	257   117	BWT 36 S 96 - BG	96	2438	40   1016	293   133	6
BWT 24 S 108 - BG	108	2743	40   1016	262   119	BWT 30 S 108 - BG	108	2743	40   1016	290   132	BWT 36 S 108 - BG	108	2743	40   1016	331   150	6
BWT 24 S 120 - BG	120	3048	40   1016	285   130	BWT 30 S 120 - BG	120	3048	40   1016	315   143	BWT 36 S 120 - BG	120	3048	40   1016	361   164	6

\* Custom sizes also available

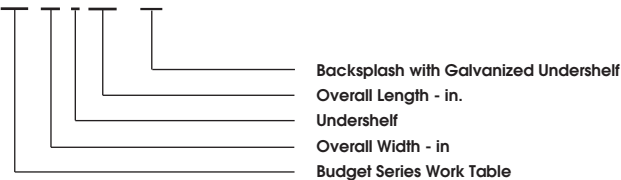

Elkay SSP  
 421 N. Freya St.  
 Spokane, WA 99205  
 Phone: 800-726-0553 Fax: 509-535-1493

Website: www.sspinc.net  
 Email: sspsales@elkay.com  
 ©2011 Elkay