



PROJECT: _____
 LOCATION: _____
 ITEM#: _____
 QUANTITY: _____

COMPETITOR SERIES®



BIG TOP SANDWICH PREPARATION TABLES

- Beautiful ergonomic construction & rounded corners
- Electro-mechanical thermostat with thermometer read-out (Mid Year 2015: Digital temperature controller & read out)
- All stainless steel exterior and interior
- Forced air refrigeration system
- 9 1/4" deep cutting board included
- Recessed door handles
- Pre-installed casters and shelving
- 90 degree hold open door feature for loading products
- Migali® Protection Plan: 1 Year Parts & Labor Warranty, 5 Years Compressor Warranty

MODEL	DOORS	Num. of 1/6 Size Pans*	Cu/Ft	SHELVES	H/P	AMPS	VOLTAGE	WEIGHT(lbs)	ENERGY CONSUMPTION Kwh/24hr	PLUG TYPE	DIMENSIONS L x D x H	TEMPERATURE RANGE
C-SP27-12BT	1	12	6.5	1	1/4	3.3	115/60/1	209 lbs.	2.6	Nema 5-15P	27.5" x 34" x 46.6"	+33° F (-) +41° F
C-SP48-18BT	2	18	12	2	1/3	5.1	115/60/1	253 lbs.	3.6	Nema 5-15P	48.2" x 34" x 46.6"	+33° F (-) +41° F
C-SP60-24BT	2	24	18.2	2	1/2	5.1	115/60/1	338 lbs.	3.6	Nema 5-15P	60.2" x 34" x 46.6"	+33° F (-) +41° F
C-SP72-30BT	3	30	24.5	3	1/2	5.7	115/60/1	387 lbs.	4.1	Nema 5-15P	72.7" x 34" x 46.6"	+33° F (-) +41° F

* MIGALI® RESERVES THE RIGHT TO CHANGE SPECIFICATIONS WITHOUT NOTICE

* NOTE: PAN BARS ARE INCLUDED
 * NOTE: PANS ARE NOT INCLUDED

* TOTAL HEIGHT INCLUDES CASTERS



TOLL FREE: 800.852.5292
 WEB: www.migali.com



Conforms to NSF 7 Foodservice

MIGALI® REMAINS AN AMERICAN FAMILY COMPANY SINCE 1955

DIMENSIONAL DRAWINGS

C-SP27-12BT

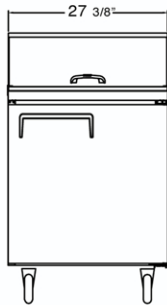

C-SP48-18BT

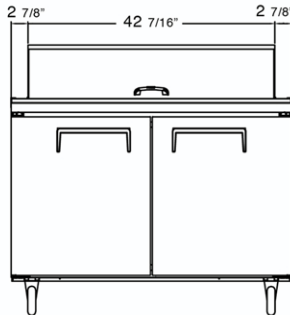

C-SP60-24BT

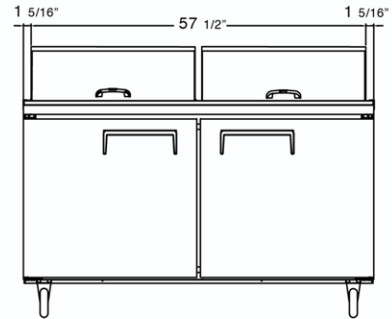

C-SP27-12BT TOP VIEW

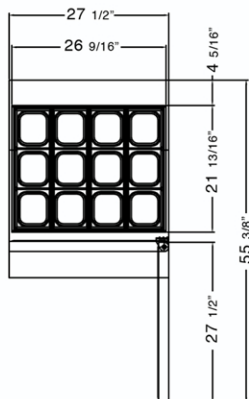

C-SP48-18BT TOP VIEW

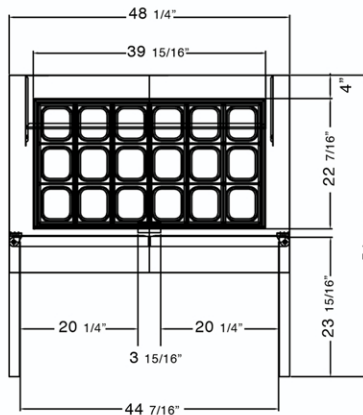

C-SP60-24BT TOP VIEW

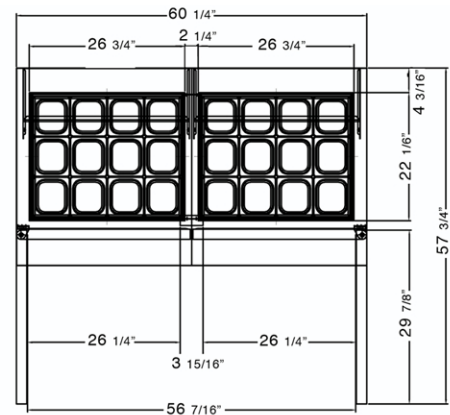

C-SP72-30BT

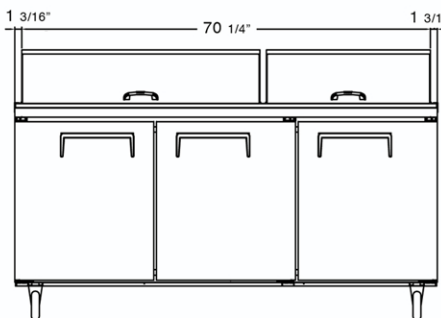

C-SP72-30BT TOP VIEW

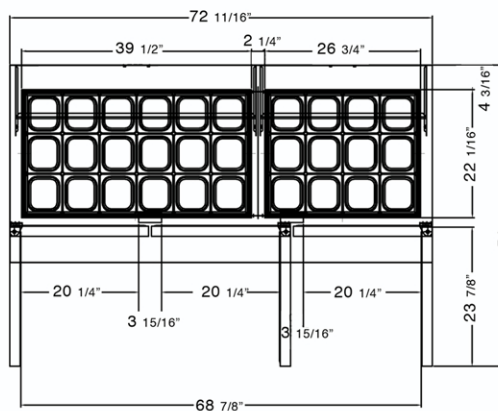

SIDE VIEW(1,2,3 DOOR)

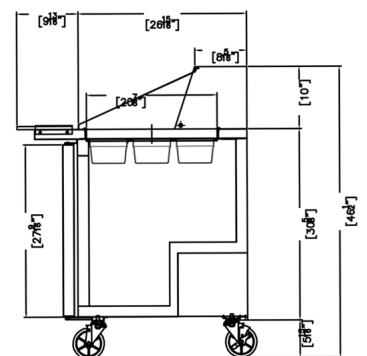

TOLL FREE: 800.852.5292

FAX: 856.963.3604

EMAIL: contact@migali.com

WEB: www.migali.com



MIGALI® REMAINS AN AMERICAN FAMILY COMPANY SINCE 1955