

Food Service

VSI Data sheet - Depositing Table (DT) VSI 330F DT-400 / VSI 330F DT-W-400

BIZERBA

Intelligent slicing – the fully automatic vertical slicer VSI table-top version combines precision to target weight at a high throughput and a networked integration in the production process. The individual solution for more flexibility and efficiency in the kitchen prep area.



More information
High performance with a wide range of solutions and options.

Product description

Bizerba slicer VSI offers a configurable solution for use in the foodservice industry, in large prep kitchens. High slicing performance with minimal energy consumption due to Emotion® technology.

Labor & Space Savings - ideally suitable to replace three (3) manual slicers and three (3) workers with one (1) VSI 330F DT and one (1) worker. For large production quantities in a little space. Also suitable for manual further processing of sliced and ready-made portions directly into batch packaging, box lunches or onto a platter.

The easy to customize touch operator prompting and the possible integration in IT network structures make the VSI a safe investment that helps to improve efficiency of your processes.

As a table-top version the VSI can be ideally integrated in the processes of a space saving modern versatile commercial kitchen.

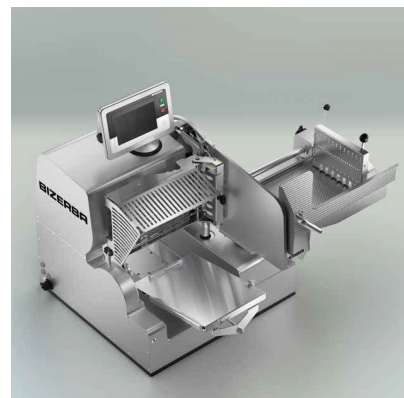

VSI 330F DT-400

Highlights

- Integrated portion scale (W) for target weight control including weight optimization within a portion.
- Hygienic design for hose cleaning up to 50 psi. Optimal cleaning and easy disassembly without tools. The housing shape prevents product residues or liquids from soiling the environment during operation.
- Hygienic component design - allows much faster and more thorough deep cleaning in commercial dish/pan washer.
- Personalized, future-oriented touch operator ergonomics with individual user profiles and messaging functions (to plan preventative maintenance or in the event of operating errors), monitoring functions (history of all actions, degree of utilization of the machine) up to possible e-Service via the Bizerba Service.
- Data and control system related signal exchange ensure an optimal integration in customer and line processes.



Integrated scale: VSI 330F DT-W

Warranty

The VSI carries a one-year, on-site parts and labor warranty against any flaws in materials and workmanship. This period begins with the date of purchase and, provided the unit is used properly in accordance with our instructions, is in full effect for one year from that date. Any work to be performed under this warranty must be performed between the hours of 8:00 a.m. and 4:30 p.m. local time, Monday to Friday. Bizerba will not pay overtime charges for work performed other than during normal business hours. Accessories have a 30-day replacement or repair warranty for the period beginning on the date of purchase. Damages incurred in transit or from installation error, accident, alteration or misuse are not covered. Transit damages should be reported to the carrier immediately. Bizerba shall not be liable for any consequential, compensatory, incidental, or special damages. All warranty work must be performed by a factory authorized Bizerba Service Representative.



Customized touch operating panel

Bizerba Food Service Included Services & Equipment

- VSI SlicerGard™ Service Protection Plan, One-year Full Service Contract with one preventative service call, included. This period begins with date of purchase and is in full effect from that date.
- Slicer Starter Kit (grinding disks and cranked ring spanner for replacement, paper felt, cover).
- Installation, Start-up, Programming & Training.
- Stand mobile with locking casters, included.
- Depositing Table (DT), included (no scale).
- Integrated portion scale with tendency control during weighing of portions (DT-W).

Optional Services & Equipment

- VSI SlicerGard™ Service Protection Plan, Full service contract. Additional coverage can be purchased from 12 months up to 60 months.
- VSI Check-up Service, available by quarter, semi-annual or annual.
- Extra, 13" Grooved vacuum release / cheese blades.
- Mechanical and control system related interfaces to external systems such as interleavers, tray dispensers and packaging machines.

Food Service

Fact Sheet - Depositing Table (DT) VSI 330F DT-400 / VSI 330F DT-W-400

BIZERBA

Intelligent slicing – the fully automatic vertical slicer VSI combines precision on target weight at a high throughput and a networked integration in the production process. The individual solution for more flexibility and efficiency in the fresh food area.



More informationen
High performance
with a wide range of
solutions and options.

Specifications	Facts	Details
Dimensions		
Installation area	858 x 1259 mm / 33.8" x 49.6" (L x W)	Installation on stand
Work area	936 x 1354 x 773 mm / 36.9" x 53.3" x 30.4" (L x W x H)	For version with a product length of 600 mm, maximum for all variants
Electrical data		
Voltage	100-120 V 50/60 Hz	Alternating current
Rated current consumption	5.8 A	Depending on selected voltage
Protection class	IPx5	Suitable for hose cleaning, individual components can be cleaned in the dishwasher
Performance data		
Product size	50 x 50 mm / 1.97 x 1.97" Up to 240 x 180 mm / 9.45 x 7.1" (W x H) Round products 50 - 180 mm / 1.97 - 7.1"	
Slice thickness	0.3 - 12 mm / 0.01 - 0.5"	Motorized adjustment, in PLU data storable
Product length	440 mm / 15.75" (-400mm Carriage, standard)	
Slicing performance	up to 30- 80 slices per minute	Slicing performance depending on depositing pattern and product to be sliced
Operation	Configurable touch display	
Installation	Mobile stand, adjustable feet during operation, standard	
Gross weight	115 kg / 254 lb	Weight without stand
Housing materials	Stainless steel and anodized aluminum Plastics	complies with regulation (CE) No. 1935/2004 complies with regulation (CE) No. 10/2011
Options		
Control interface	I/O interface Retroreflective sensor Proximity sensor	24 V for downstream machines and interleaver
Scale VSI 330F DT-W	Integrated portion scale with tendency control within a portion Weighing range: 50 - 2000g / 1g	For portions of up to 240 mm crosswise to transport direction and 255 mm in transport direction
TCP/IP	Data interface to Bizerba PC systems	
Mobile Stand	Robust version in stainless steel	With castors and locking function for mobile version

Infographic



Symbols



CE



DGVU tested
(GS)



ETL
Sanitation



Intertek
UL/cUL



VDMA



BLUECOMPETENCE
Alliance Member
Partner of the Engineering Industry
Sustainability Initiative



Dimensions

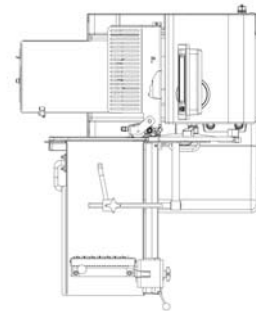
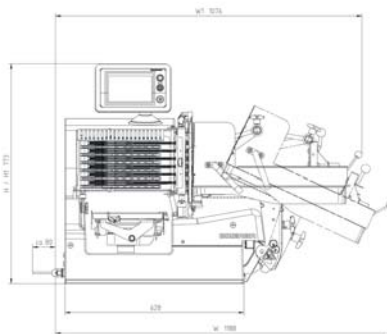
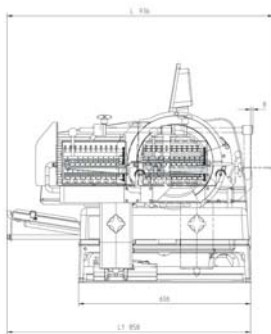

Members of the Bizerba Group

Bizerba GmbH & Co. KG
Wilhelm-Kraut-Straße 65
72336 Balingen
Germany
Tel. +49 7433 12-0
Fax +49 7433 12-2696
marketing@bizerba.de
www.bizerba.com

Bizerba USA Inc.
1804 Fashion Court
Joppa, MD 21085
USA
Tel. Office +1 732 565-6000
Tel. Service +1 732 565-6001
Fax +1 732 819-0429
us.foodservice@bizerba.com
www.bizerba.com

Bizerba Canada Inc.
6411 Edwards Blvd.
Mississauga, Ontario L5T2PT
Canada
Tel. +1 888 240-3722
French Tel. +1 877 699-2199
Fax +1 905 816-0497
ca.info@bizerba.com
www.bizerba.ca

Bizerba de México, S.A. de
C.V. Av. Rio Mixcoac No. 157
Colonia Florida
01030 México, D.F.
México
Tel. +52 55 5663-1397
Fax +52 55 5663-1296
contacto@bizerba.com.mx
www.bizerba.com.mx



Full service contract



More Information
High performance
with a wide range of
solutions and options.

My Bizerba Full service contract – an all-round service contract for Bizerba hardware and software. The flexible design of the contract enables us to create a service package individually tailored to your needs.

The Full service contract is a Bizerba Complete contract. Our complete protection for your investments.

Full
service
contract

Our services at a glance

Annual check-up:

- Inspection based on a detailed device-specific check list
- Safety inspection as per VDE 0701/0702

Remote Support:

- Use of technical hotline
- Quick online support without on-premise assignment
- Checking of error messages for hardware and software as well as identification of possible error causes

Repair Services:

- Repair of defect devices
- Set-up time
- Working time
- Travel expenses
- Other expenses
- Original Bizerba spare parts included (with the exception of wear and tear parts: i.e. blade knife, honing and sharpening stone discs, remnant plate holder, etc.)

Software Maintenance:

- Transfer of updated versions for the licensed software modules

Asset Management:

- Survey of devices at customer site, e.g. for inventory purposes

Your benefit

With the Full service contract you benefit from greater planning reliability and cost certainty. Regular preventative servicing ensures that the value and functionality of devices and systems remains intact. This ensures a high level of availability and productivity for your company. The Full service contract also helps minimize the number of unforeseeable repairs, internal assignments as well as training and personnel costs.

If the system still shuts down – with a Full service contract you're on the safe side. Stand-by services during our business hours are included, meaning that repairs can be done quickly. Production downtime can be reduced thanks to quick assistance provided by our remote support service – without technician lead time and travel time. Benefit further from what this saves you in terms of time.

Another advantage you can expect from the Full service contract is the use of Bizerba spare parts. The use of high-quality and tested original Bizerba spare parts increases the life span and working life of the devices, providing more reliable availability and greater economic viability.

Always up to date with the latest version of the software on your devices – that's what you will be, automatically and without any additional costs, thanks to the integrated software maintenance service in the Full service contract. You have the latest functions at your fingertips and productivity is continually optimized – then you can react quickly to any statutory changes.

The desire for a simple payment method, predictable costs, cost control and transparency is provided with this type of contract – as internal costs and time are saved if you take advantage of the Full service contract. And what is more, you always know what kind of costs are to be expected as a result of the purchase and operation of the system (TCO) at the time

of investment.

Bizerba Service is a competent partner, who knows the ins and outs of your situation and your requirements and can respond to them individually and personally. With the Full service contract from Bizerba you gain a reliable and proactive partner and solution provider as the central body to register your requirements. Get the maximum benefit from Bizerba technicians' professional process and industry know-how. Thanks to the Bizerba principle "Everything from a single source" you will be in good hands with us.

Special features

By using original Bizerba spare parts you meet the warranty claim for devices and systems. The provision of rental devices, included in the scope of services, quickly bridges any downtime. Standstill periods and sales losses are reduced to a minimum.

In terms of verification, the Full service contract includes advice on observing the standards and statutory regulations as a matter of course – as in Bizerba Service you have a trained, competent partner who knows all about the applicable regulations. This ensures prompt statutory certification.

Our in-house established information management makes sure our service technicians are always informed and up to date on all the hygiene and security regulations.

Thanks to regular checks of your devices we always know where your device are. And large (stores) plants benefit especially here when carrying out their inventory.

Options

- Wear and tear parts included
- Increase of Service Level Agreement (SLA): Extended availability means that the stand-by service adjusts their availability by up to 24 hours, seven days a week to your individual production times. And the reaction time that you define to ensure quick and competent maintenance guarantees and ensures for the quickest possible recovery time.
- Increase in preventative service intervals
- Runtime between 12 and 60 months

Bizerba SE & Co. KG Wilhelm-Kraut-Straße 65
72336 Balingen
Germany
T +49 7433 12-0
F +49 7433 12-2696
marketing@bizerba.com
www.bizerba.com

Bizerba USA Inc.
1804 Fashion Court
Joppa, MD 21085
USA
Tel. Office +1 732 565-6000
Tel. Service +1 732 565-6001
Fax +1 732 819-0429
us.foodservice@bizerba.com
www.bizerba-na.com

Bizerba Canada Inc.
2810 Argentia Road #9
Mississauga,
Ontario L5N 8L2 Canada
Tel. +1 905 816-0498
Fax +1 905 816-0497
sales@bizerba.ca
www.bizerba.ca

Emotion

Energy Efficiency



Emotion® represents an intelligent engine concept that adapts the engine's performance to the resistance of the product. The benefits: energy efficiency and hygiene on a new level.

Highlights

- Intelligent engine control: the engine adapts its performance to the resistance of the product.
- The device's usage of power is markedly lowered.
- Compared to prevalent devices the surface stays cool and provides a better hygiene.
- Less radiated warmth – food in the deposition area stays fresh longer.
- A big added value of energy efficiency



Sustainable product development

Experts forecast that the electricity rate will increase further in the years to come. The German Engineering Federation VDMA (Verband Deutscher Maschinen- und Anlagenbauer) has founded the initiative "Blue Competence" on this background. The intention is to create a consciousness for sustainable product development and to provide information on what is important concerning durability and energy efficiency in production. Also, the initiative announces what has been achieved in this regard and which requirements have yet to be fulfilled. The aim is to produce devices that safeguard productivity with minimal usage of energy in order to protect the environment and spare the user's purse. Bizerba belongs to this initiative and invests high efforts in research in order to improve its food processing devices' energy efficiency.

Especially for the slicing mode we have developed the intelligent engine control Emotion®. Provided with this control the engine adapts its performance to the resistance of the product. The blade's rotational speed stays the same, the exertion of force increases by higher supply of energy with sluggish products only. Thus the machine uses markedly less power on average and stays cooler – a clear hygienical advantage. Now it is possible to install a closed bottom panel without vent holes. The risk of hidden soiling is markedly reduced. Moreover, the machine only radiates little warmth so that food in the deposition area is less warmed up and stays fresh longer. With Emotion® we connect two basic pillars of our food processing devices: energy efficiency and hygiene.

Bizerba SE & Co. KG
Wilhelm-Kraut-Straße 65
72336 Balingen
T +49 7433 12-0
F +49 7433 12-2696
info@bizerba.com

www.bizerba.com

BIZERBA